

MORE FOR YOUR X2 SOLUTION.

X2 Solution Accessories

FEATURES	MODEL	
	X2-6	X2-8
Extended Spinner Chute Assembly	00125-027-01	00125-027-01
Vibrator Kit	00002-615-00	00002-615-00
Pre-Wet Kit	00125-035-00	00125-035-00
Side Extension	00125-036-00	00125-036-01
Work Light / Brake Light	Work: 04605-351-00	Brake: 04605-350-00
GPS Ground Speed Control Kit	00002-617-00	00002-617-00
Tarp Kit	04034-037-00	04034-037-01
Top Screen	00125-033-01	00125-034-01

VEHICLE LOADING

Spreader Capacity

GRANULAR VOLUME AT SPECIFIED HEIGHT (CU. YDS.)

Spreader	Full	24"	12"
6'	1.50	0.61	0.11
8'	2.00	0.84	0.15

LIQUID VOLUME AT SPECIFIED HEIGHT (GALLONS)

Spreader	Full	19"	9"
6'	175	149	80
8'	225	196	107

GRANULAR VOLUME AT SPECIFIED HEIGHT (M3)

Spreader	Full	24"	12"
6'	1.15	0.47	0.08
8'	1.53	0.64	0.11

LIQUID VOLUME AT SPECIFIED HEIGHT (LITERS)

Spreader	Full	19"	9"
6'	663	564	303
8'	852	742	405

SIDE EXTENSION GRANULAR CAPACITY

Spreader	Cu. Yds.	M3
6'	0.59	0.45
8'	0.83	0.63

STEP-UP TO X2 SOLUTION WITH BUILT-IN PRE-WETTING.

One of the many features found on the standard X2 Solution is an integrated pre-wet system included in the side of the hopper.

Why Pre Wet? Pre-wetting ice-melt material helps speed up the melting process and reduces how far the granules bounce when they hit the pavement. This means you'll apply activated material more precisely, while reducing the amount of ice-melt being applied. The end result is a safer surface using less material and less application time.



3 Tarp keeps the elements, dirt, and grime off the X2 Solution when not in use to prolong the life.

5 Built-in Fill Port makes it easy to add liquid.



Controller

Provides independent motor control for auger and spinner. Additional functions include pre-wet, blast, pause, LED work light, vibrator, and optional GPS ground speed control. Standard on X2 Solution.



Built-in Pre-wetting System (optional) No hard-to-install tanks to add, and the system is fully plumbed with high-quality hoses and spray system. Plus an additional auxiliary switch.

2 Sight Indicator shows liquid levels at a glance.

4 LED Light is standard on the X2 Solution.

Swenson Spreader LLC
127 Walnut St.
Lindenwood, IL 61049

phone **815.393.4455**
fax **815.393.3320**

X2 SOLUTION SPREADERS



IT'S WHAT WE KNOW.

SWENSON

www.swensonproducts.com

Easier to use | Easier to maintain | Easier on the vehicle

Equipment | Materials | Solutions
SWENSON
IT'S WHAT WE KNOW.

A MATERIAL DELIVERY SYSTEM DESIGNED TO SAVE YOU TIME & MONEY.

The X2 Solution's electric-driven material delivery system is like nothing you've ever seen. It is designed to efficiently and consistently deliver the proper amount of ice-melt material when and where you need it.

Here's how it works:

- 1 Hopper screen eliminates large chunks of material from entering the hopper.
- 2 The material routing system uses a tapered inverted V design that evenly routes the material to the auger drive, from the back of the hopper forward.
- 3 A heavy-duty vibrator (optional) helps break up chunks and promotes an even distribution of material going into the auger drive.
- 4 Then a patent-pending, full-length auger smoothly and consistently empties the entire hopper, from the back forward. The auger consists of one solid part and requires less maintenance.
- 5 The auger is driven by a heavy-duty ½ HP motor and gear box that can be quickly removed for cleaning and maintenance.
- 6 The independently controlled spinner manages material output to help reduce consumption and lets you precisely spread the material where you need it.

No-Tools, Easy Maintenance Spinner Assembly*

- A Tongue and groove design allows for "no tools" removal
- B Concealed spinner motor compartment keeps salt out
- C Independent controlled 1/8 hp motor for precise material placement
- D Angled chute provides improved material distribution
- E Low-friction poly bearings require no maintenance
- F Integrated spinner guard also controls where material is placed
- G Integrated handles for easy spinner assembly removal

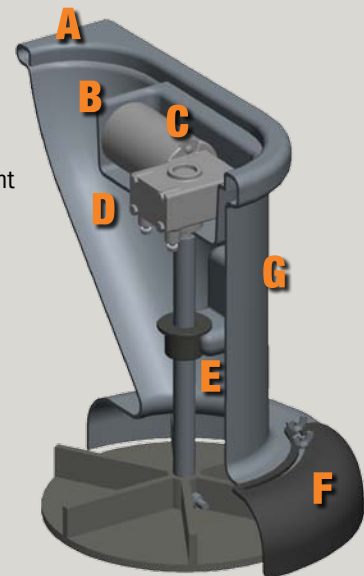

* Patent Pending



Full-width hopper reduces material spillage into the vehicle bed to prevent corrosion.

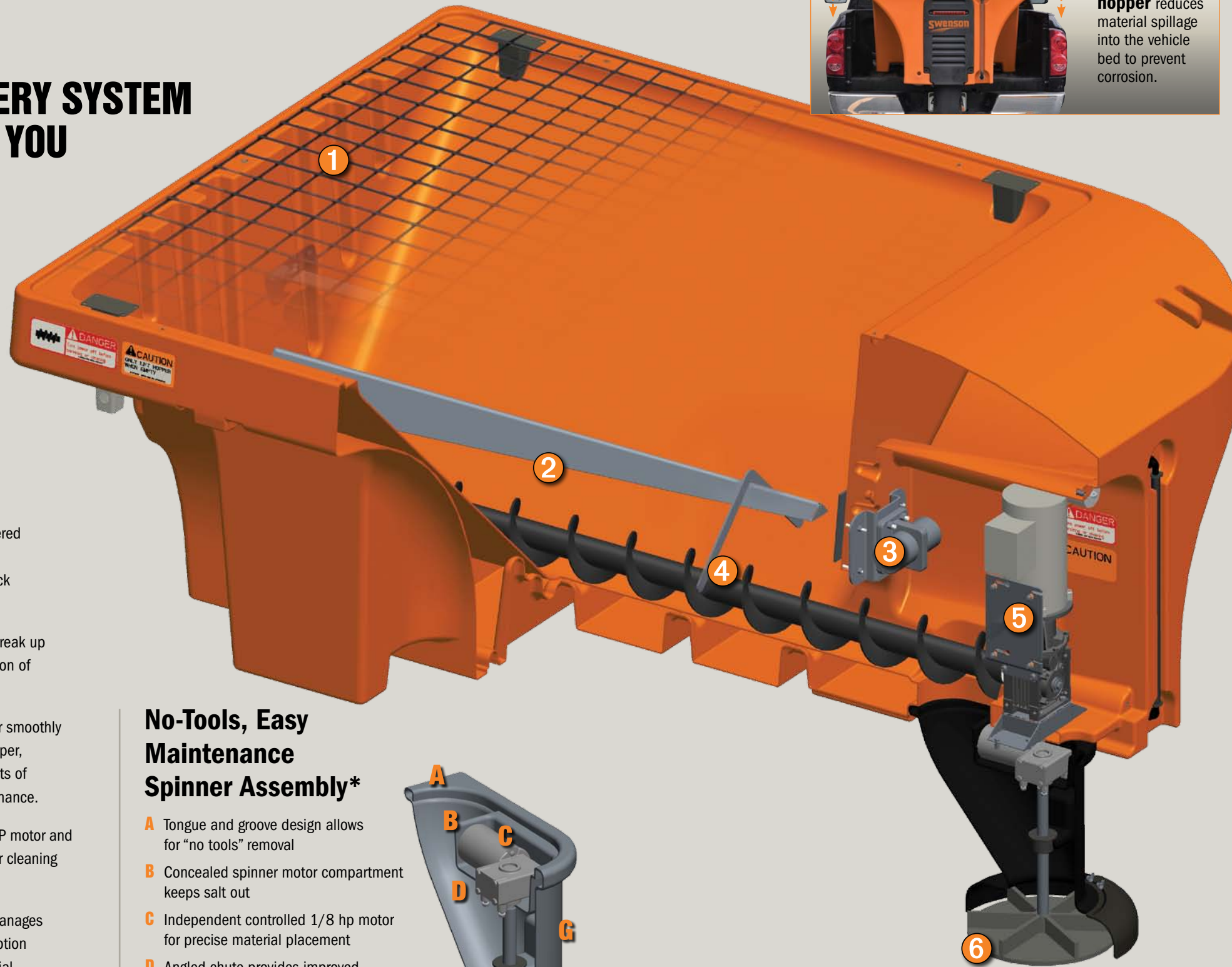

Thoughtful features, premium performance.



Integrated work light illuminates spread area and helps in maintenance operations. LED light standard.



Built-in tarp hooks are engineered into the hopper making tarp installation and removal quicker and easier.



Recessed lifting pockets make it easy to install or remove from the vehicle and can easily be placed upright for off-season storage.



In the off-season the X2 Solution can be placed upright saving valuable storage space.

The X2 Solution practically takes care of itself.



Spinner assembly requires no tools for removal or maintenance.



Auger assembly can easily be removed for maintenance or inspection.



Rear cover protects auger motor from salt and debris. Panel can be easily removed.



Low-friction poly bearing requires no lubrication or tools to hold the auger in place.

STANDARD MODEL FEATURES AND PRODUCT SPECIFICATIONS.

Standard Model Features

FEATURES	MODEL	
	X2-6	X2-8
Vibrator	Optional	Optional
Material Delivery System	Auger	Auger
Pre-Wet System	Optional	Optional
Tarp System	Standard	Standard
Ground Speed Controller	Standard	Standard
Top Screen	Standard	Standard
Work Light	LED	LED
Motor System	Dual Electric	Dual Electric
Controller	Dual speed with auger/spinner control	Dual speed with auger/spinner control
Warranty	1 year	1 year

Standard Model Specifications

PRODUCT SPECS	MODEL	
	X2-6	X2-8
Vehicle	¾-1-ton pick-up	¾-1-ton pick-up
Capacity (cubic yard)	1.5	2.0
Hopper Construction	Poly	Poly
Overall Length (inches)	93.5"	117.5"
Overall Height (inches)	37"	37"
Overall Width (inches)	70"	70"
Weight (empty)	510 lbs.	625 lbs.
Spread Width (feet)	40 ft.	40 ft.
Material (dry, free-flowing material)	Salt, salt/sand mix	Salt, salt/sand mix
Mounting	Strap	Strap