

INSTALLATION AND OPERATING INSTRUCTION MANUAL

Read Before Installation

APB - ALL PURPOSE BODY 7 FT. THRU 11 FT. MID SIZE 8 FT. THRU 18 FT. FULL SIZE



INCLUDED IN THIS MANUAL:

SAFETY PRECAUTIONS	2	Body Operating Instructions	21
Hydraulic Specifications & Installation	6	Adjusting Front and Rear Spinners	26
Mounting Body, Hoist and Prop	13	For Desired Spread Patterns	
Installing Front Spinner Assembly	16	Recommended Regular Maintenance	31
Installing Rear Spinner Assembly	18	Parts Drawings and Parts Lists	32
Installing Conveyor Cover Assembly	20	Nameplate Information	62
		Warranty	Back Page



SAFETY PRECAUTIONS

The best safety device is a careful operator!



This symbol means ATTENTION!
Become Alert!
Your safety is involved!
Please read and understand completely before doing!

 **Improper use of this equipment can result in serious injury. To reduce this possibility, give complete and undivided attention to the job at hand, and follow these safety precautions.**

PREPARATION

Know your controls. Read this instruction manual. Learn how to stop the equipment quickly in an emergency.

Do not allow children to operate machine; nor adults to operate it without proper instructions.

Keep all individuals not involved in the use of the equipment a safe distance away.

OPERATION

Observe and shut off all equipment controls before starting engine so equipment will not unintentionally operate when engine is started.

Always check area around machine before engaging or operating controls.

Always wear relatively tight and belted clothing when operating equipment. Loose jackets, shirts sleeves or other loose clothing should not be worn because of the danger of catching them in moving parts or controls.

Stop and inspect equipment if unusual movement, sounds or noises are observed. Repair damage before restarting and operating the equipment.

Disengage power to all operating equipment: (1) before leaving operator's position, (2) before making any repairs or adjustments, or (3) when not in use.

Take all possible precautions when leaving the equipment unattended; such as disengaging the hydraulic system from the vehicle engine, shifting vehicle out of gear, setting parking brake, shutting off engine and removing key.

NOTICE:

1. It is the responsibility of the dump body installer to apply all safety decals to the body in a secure manner in locations shown on pages 4 and 5 of this instruction manual.

2. It is the responsibility of the owner of the dump body to replace any or all safety decals which become unreadable or otherwise defaced.

Read and observe all "DANGER" and "CAUTION" safety decals and appearing on equipment.

The following safety decals appear in various locations on your equipment; refer to pages 4 and 5 for exact location.

The sizes of the decals shown in this manual have been reduced in order to save space. Refer to page 5 for actual size measurements.

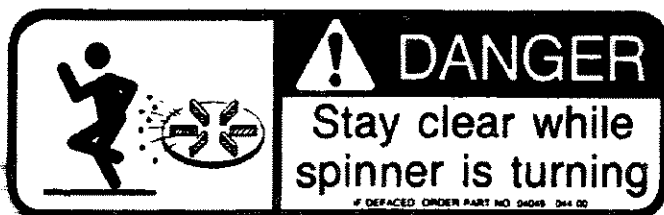

This decal appears on or near the spinner assembly on the left side of the truck chassis and ahead of the rear tires, and /or appears on or near the spinner assembly at the rear of the truck.

It alerts all to the danger of being struck by material being spread by the spinner assembly which could result in serious personal injury.

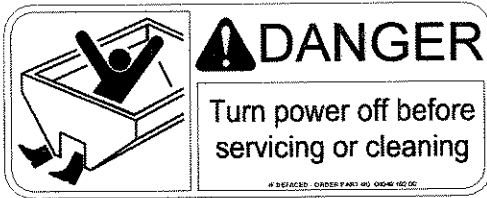

This decal appears near the top rails of the body and near the top edge of the tailgate where unsafe access can be gained to the conveyor which operates within the floor of the body.

It alerts all to the danger of being trapped inside the body and being caught in the conveyor where serious personal injury could result.

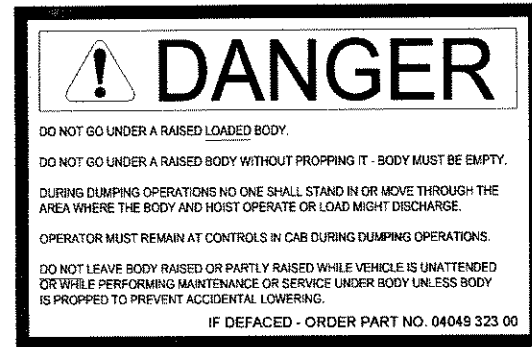

This decal appears on the left front side, and the right front side of the dump body.

It alerts all to the danger of being under a raised dump body where serious personal injury could result if the body were to come down.

It also alerts the operator to precautions necessary to eliminate other dangerous situations associated with a raised body.

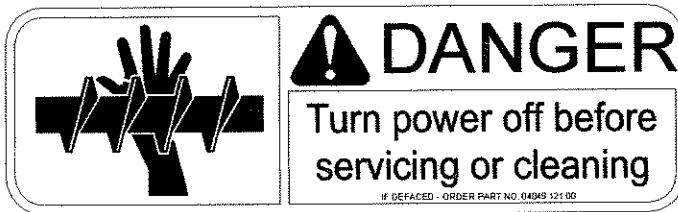

This decal appears on or near the crossauger assembly mounted up under the front of the body, where unsafe access can be gained to a rotating auger operating inside the crossauger trough.

It alerts all to the danger of being caught in the dropout opening of the crossauger where serious personal injury could result.

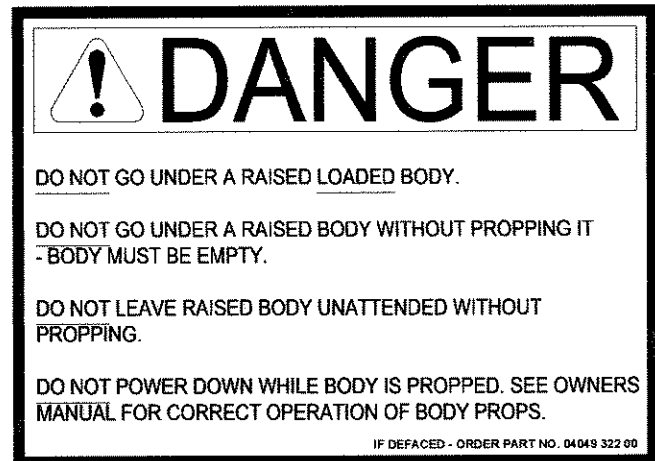

This decal appears down on the left and right sides of the truck frame.

It alerts all to the danger of being under a raised dump body where serious personal injury could result if the body were to come down.

It also alerts the operator to precautions necessary to eliminate other dangerous situations associated with a raised body.

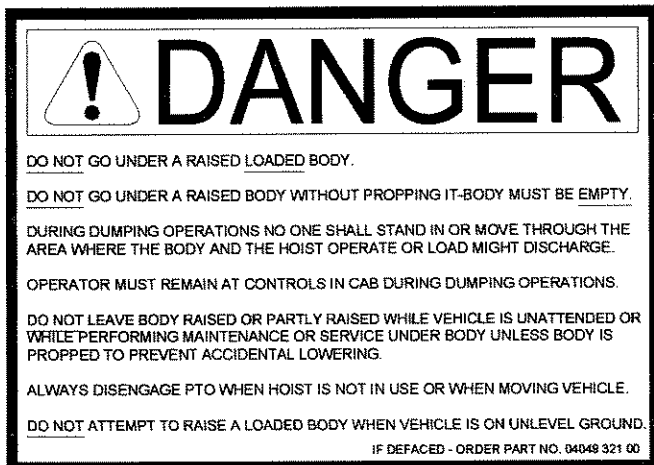

This decal appears on the left rear side, and the right rear side of the dump body.

It alerts all to the danger of being under a raised dump body where serious personal injury could result if the body were to come down.

It also alerts the operator to precautions necessary to eliminate other dangerous situations associated with a raised body.

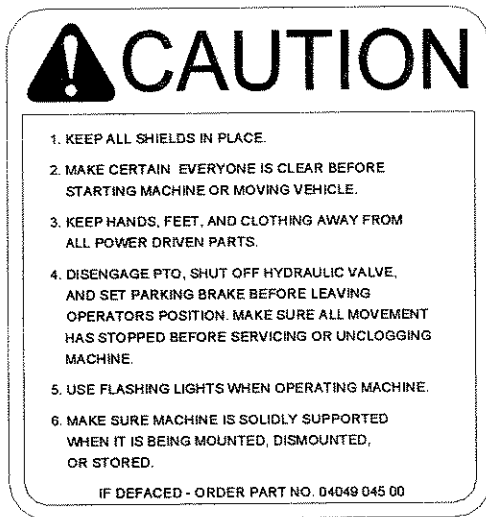

This decal appears on the left front side of the dump body.

It cautions all to observe general safety procedures when operating this equipment.

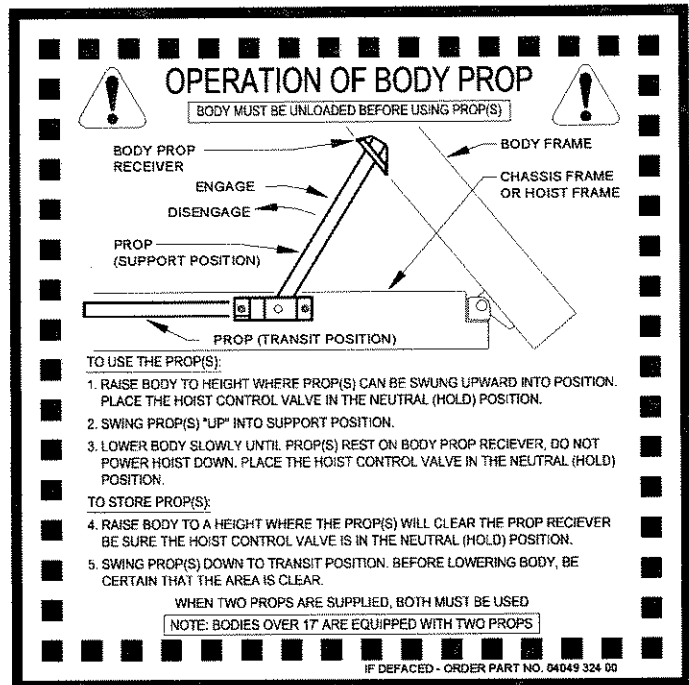

This decal appears on the left side, and the right rear side of the dump body.

It instructs the equipment operator on the safe use of the dump body prop.

LOCATION OF SAFETY DECALS

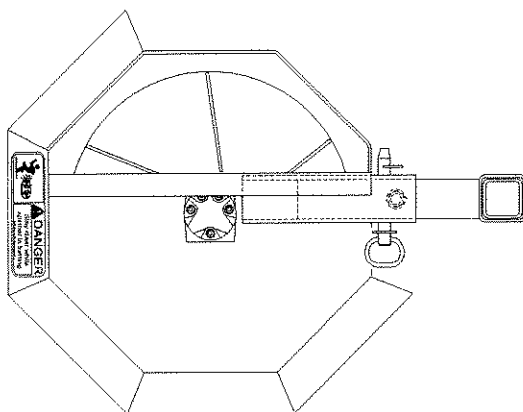

Z:\00113\39500SSD

Location of spinner danger decal (no. 04049 044 00) on front mounted spinner assembly.

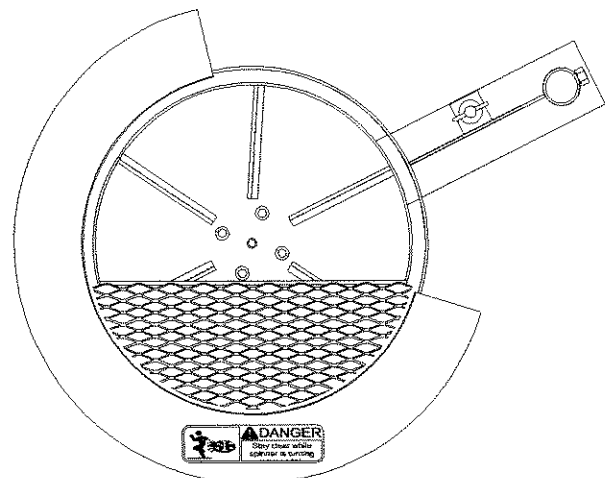

Location of spinner danger decal (no. 04049 044 00) on rear mounted spinner assembly.

LOCATION OF SAFETY DECALS

(CONTINUED)

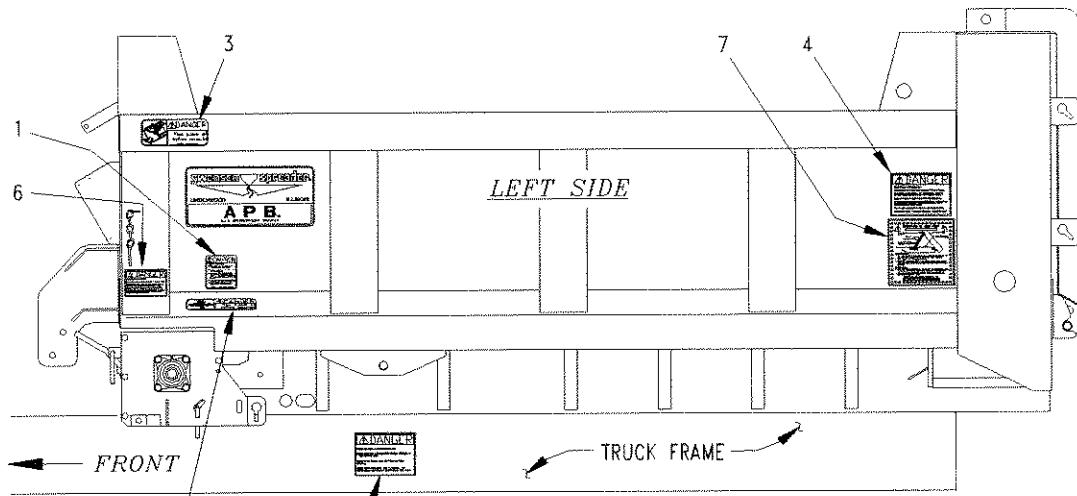

5 — MUST NOT BE OBSTRUCTED BY TIRES, RESERVOIRS, OR OTHER TRUCK FRAME MOUNTED EQUIPMENT.

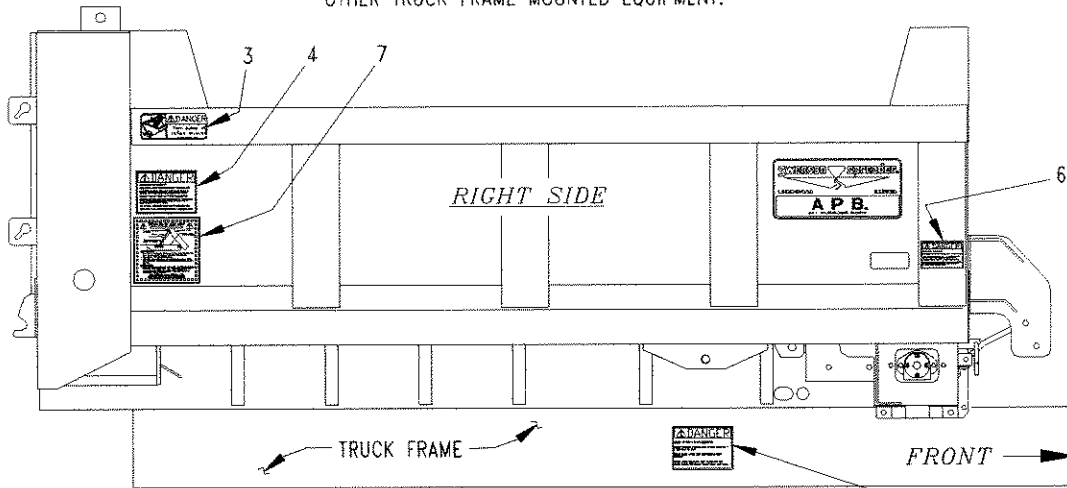

5 — MUST NOT BE OBSTRUCTED BY TIRES, RESERVOIRS, OR OTHER TRUCK FRAME MOUNTED EQUIPMENT.

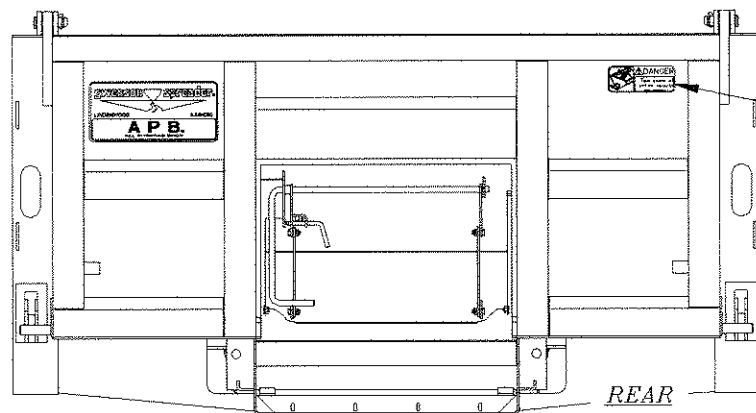

Z:\00113\39500\SD

<u>Decal</u>	<u>Part Number</u>	<u>Qty.</u>	<u>Description</u>
1	04049-045-00	1	General Caution Decal (4 1/4" x 4" yellow and black)
2	04049-121-00	1	Auger Danger Decal (9" x 2 3/4" red and white)
3	04049-182-00	3	Conveyor Danger Decal (8 1/2" x 3 3/8" red and white)
4	04049-321-00	2	Body General Danger Decal (7 3/4" x 5 1/2" red and white)
5	04049-322-00	2	Truck Frame Danger Decal (7 3/4" x 5 1/2" red and white)
6	04049-323-00	2	Body General Danger Decal (5 3/8" x 3 1/2" red and white)
7	04049-324-00	2	Prop Operation Decal (8 1/2" x 8 1/2" yellow and black)

HYDRAULIC SPECIFICATIONS AND INSTALLATION

Hydraulic Oil.....	Good grade of MS10W hydraulic oil which has wear, oxidation, and foam inhibitors
Oil Filter.....	10 micron element return line filter
Relief Valve Setting.....	1500 PSI
Minimum Oil Flow Requirement To Dual Flow Control Valve.....	.22 GPM
Maximum Oil Flow Capability To Spinner.....	7 GPM
Maximum Oil Flow Capability To Conveyor System.....	15 GPM
Maximum Working Pressure of Hoist Cylinder.....	2000 PSI

Motor For:	Motor Displacements	
	Displacement Per Revolution (Cubic Inches)	Motor Shaft Revolutions Per Minute at 1 Gallon Of Oil Per Minute (Theoretical)
Spinner	2.8	82.5
Floor Conveyor* (Single Motor)	127.69	1.81
Crossauger Conveyor	22.6	10.22

* Motors are connected in parallel on units with dual motor drive floor conveyors. As a result, conveyor shaft RPM is 1/2 that of units with single motor floor conveyor drives.

1. Dual flow control valve: The spinner and conveyor output oil flows are being controlled by a valve which is a dual flow regulator, and pressure compensated so conveyor and spinner speeds remain constant regardless of increases or decreases in pump output and/or operating pressures. This holds true as long as flow into valve is equal to (or exceeds) valve output flow requirements.

2. Motor movement during operation: The floor conveyor drive motor is torque arm mounted. As the motor operates, some movement may be observed; this is acceptable.

3. The conveyor and crossauger hydraulic circuit is connected in series. Whenever floor conveyor is operated in forward direction, crossauger conveyor operates automatically. This applies only to front drive units.

4. Diverting spinner oil flow to crossauger drive motor for berming operations: This is necessary if unit is to be used where maximum output of the crossauger is desired. The operating characteristics of the dual flow control valve enable spinner oil flow to be combined with conveyor motor oil flow to increase crossauger motor speed. Since conveyor motor(s) is

(are) connected in series with crossauger motor, this is possible.

In single conveyor motor circuits, spinner oil flow is combined with output oil flow from conveyor motor but just ahead of input port on crossauger motor. Combining these two flows as such increases only crossauger motor speed, thus increasing capability of crossauger to convey larger volumes of material received from the conveyor.

In dual motor conveyor drive circuits, spinner oil flow is combined with input oil flow to conveyor motors. Combining spinner oil with input oil parallel connected conveyor motors will increase speed of conveyor motors, as well as crossauger motor. It is desirable that conveyor motor speeds increase since same volume of oil that operates single conveyor motors also operates parallel connected dual conveyor motors.

5. The hydraulic plumbing diagrams on the following pages may be used to install an entire system, or part of a system depending upon individual requirements.

6. Alternate proven methods and components are acceptable to suit various truck model requirements.

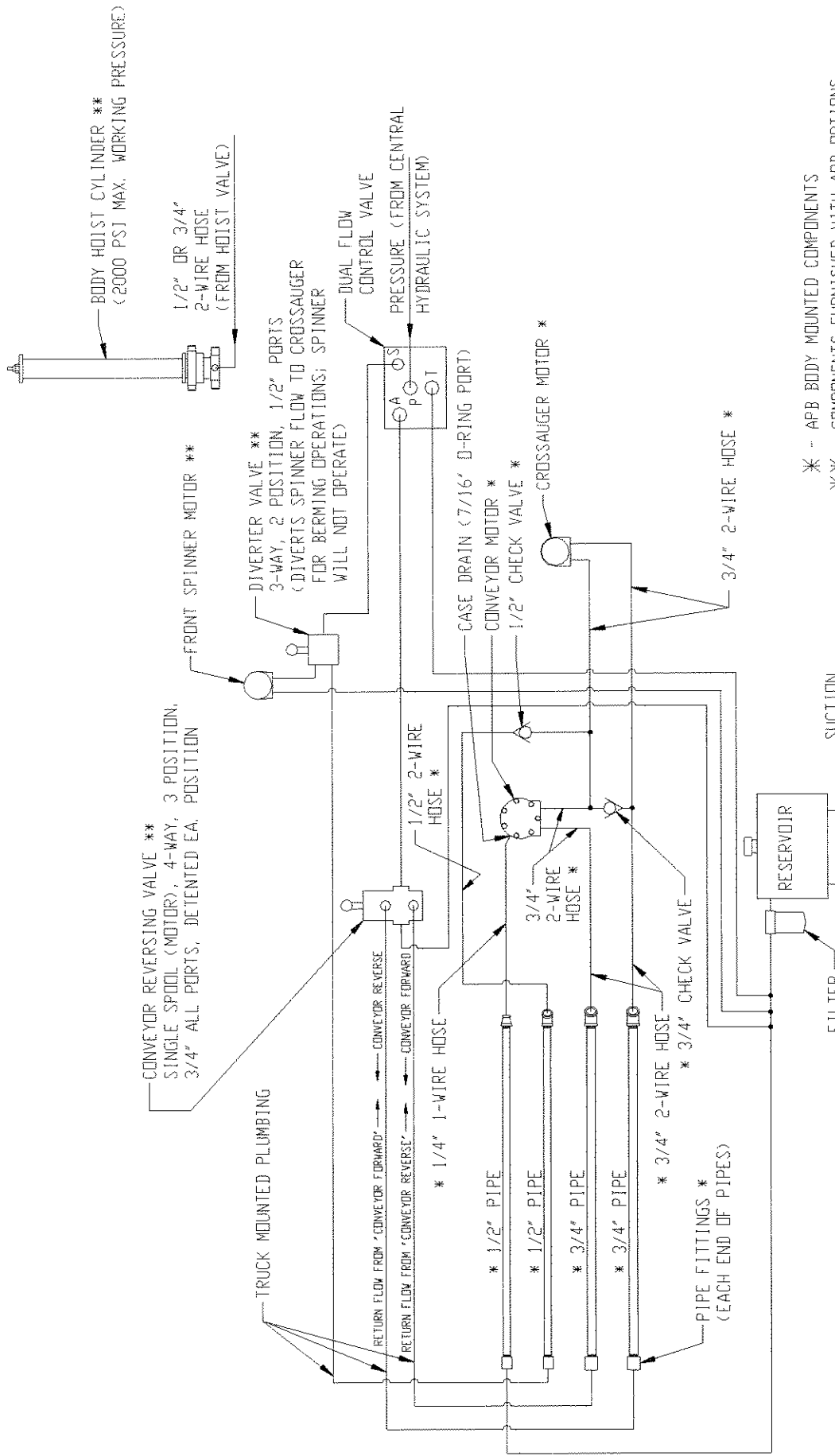

* - APB BODY MOUNTED COMPONENTS
 ** - COMPONENTS FURNISHED WITH APB OPTIONS
 --- UNLABELED COMPONENTS FURNISHED BY INSTALLER

**FRONT DRIVE
 SINGLE MOTOR PLUMBING DIAGRAM**
 (for bodies 11 ft. and under)

- NOTES:**
1. SPINNER SHOULD OPERATE IN COUNTER-CLOCKWISE DIRECTION AS VIEWED FROM TOP OF SPINNER
 2. IF A MOTOR OPERATES IN THE WRONG DIRECTION, REVERSE HOSE CONNECTIONS AT MOTOR PORTS (USUALLY EASIER)

Z:\00115\39560\Y65MFD

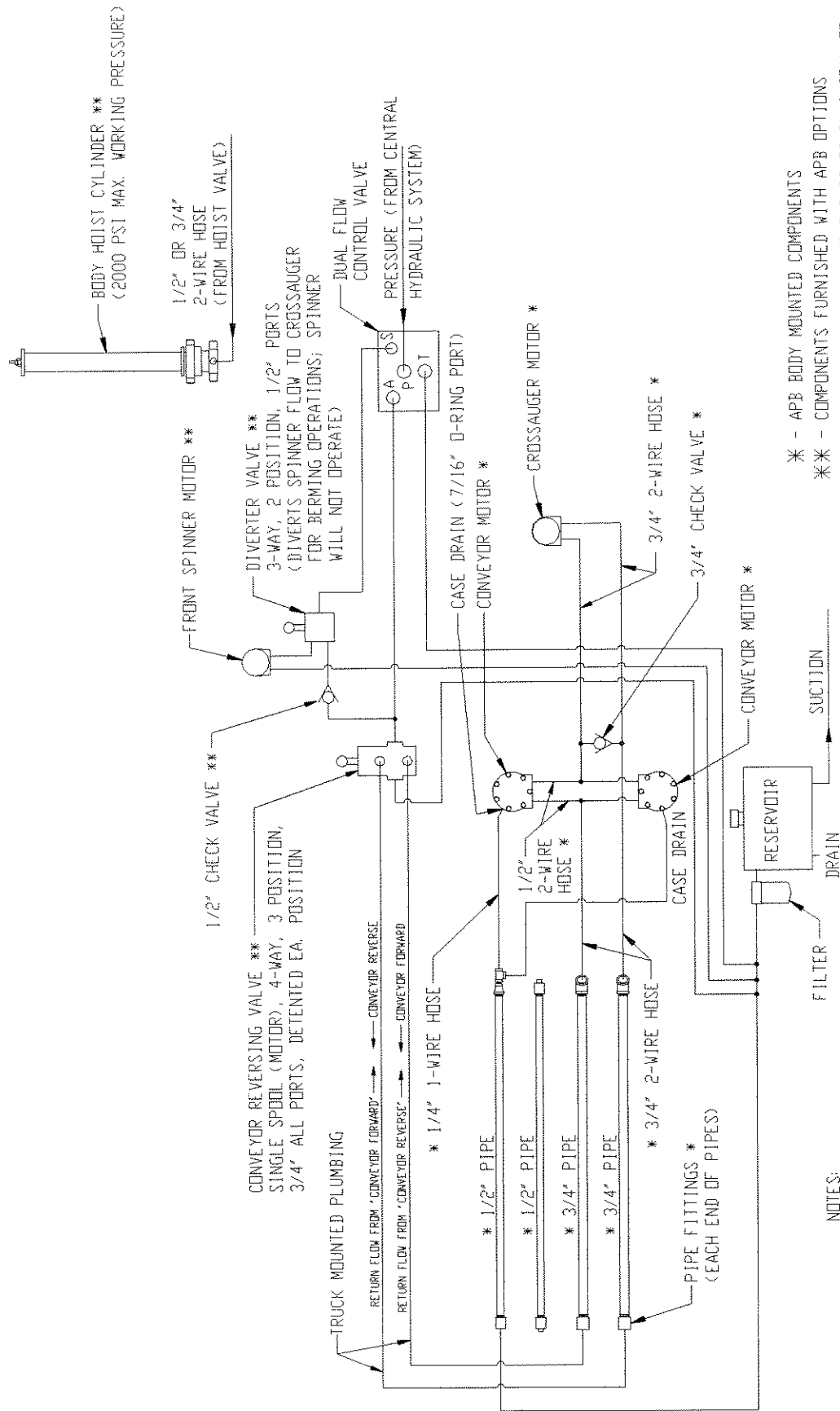

- * - APB BODY MOUNTED COMPONENTS
- ** - COMPONENTS FURNISHED WITH APB OPTIONS
- UNLABELED COMPONENTS FURNISHED BY INSTALLER

FRONT DRIVE DUAL MOTOR PLUMBING DIAGRAM (for bodies 12 ft. and over)

NOTES:

1. SPINNER SHOULD OPERATE IN COUNTER-CLOCKWISE DIRECTION AS VIEWED FROM TOP OF SPINNER
2. IF A MOTOR OPERATES IN THE WRONG DIRECTION, REVERSE HOSE CONNECTIONS AT MOTOR PORTS (USUALLY EASIER)

Z:\00113\19500\100M4P

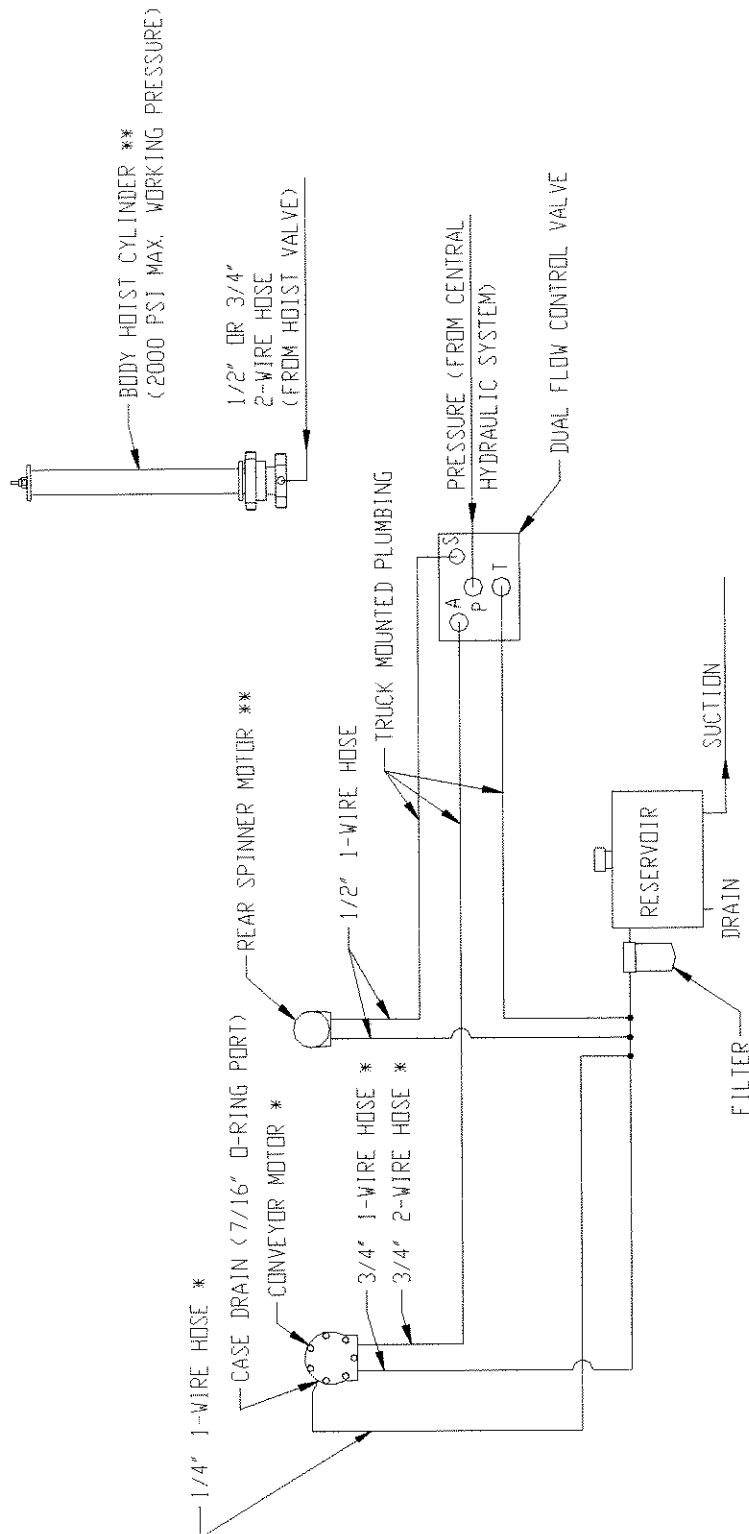

- * - APB BODY MOUNTED COMPONENTS
- ** - COMPONENTS FURNISHED WITH APB OPTIONS
- - UNLABELED COMPONENTS FURNISHED BY INSTALLER

NOTES:

1. SPINNER SHOULD OPERATE IN COUNTER-CLOCKWISE DIRECTION AS VIEWED FROM TOP OF SPINNER
2. IF A MOTOR OPERATES IN THE WRONG DIRECTION, REVERSE HOSE CONNECTIONS AT MOTOR PORTS (USUALLY EASIER)

**REAR DRIVE
SINGLE MOTOR PLUMBING DIAGRAM**
(for bodies 11 ft. and under)

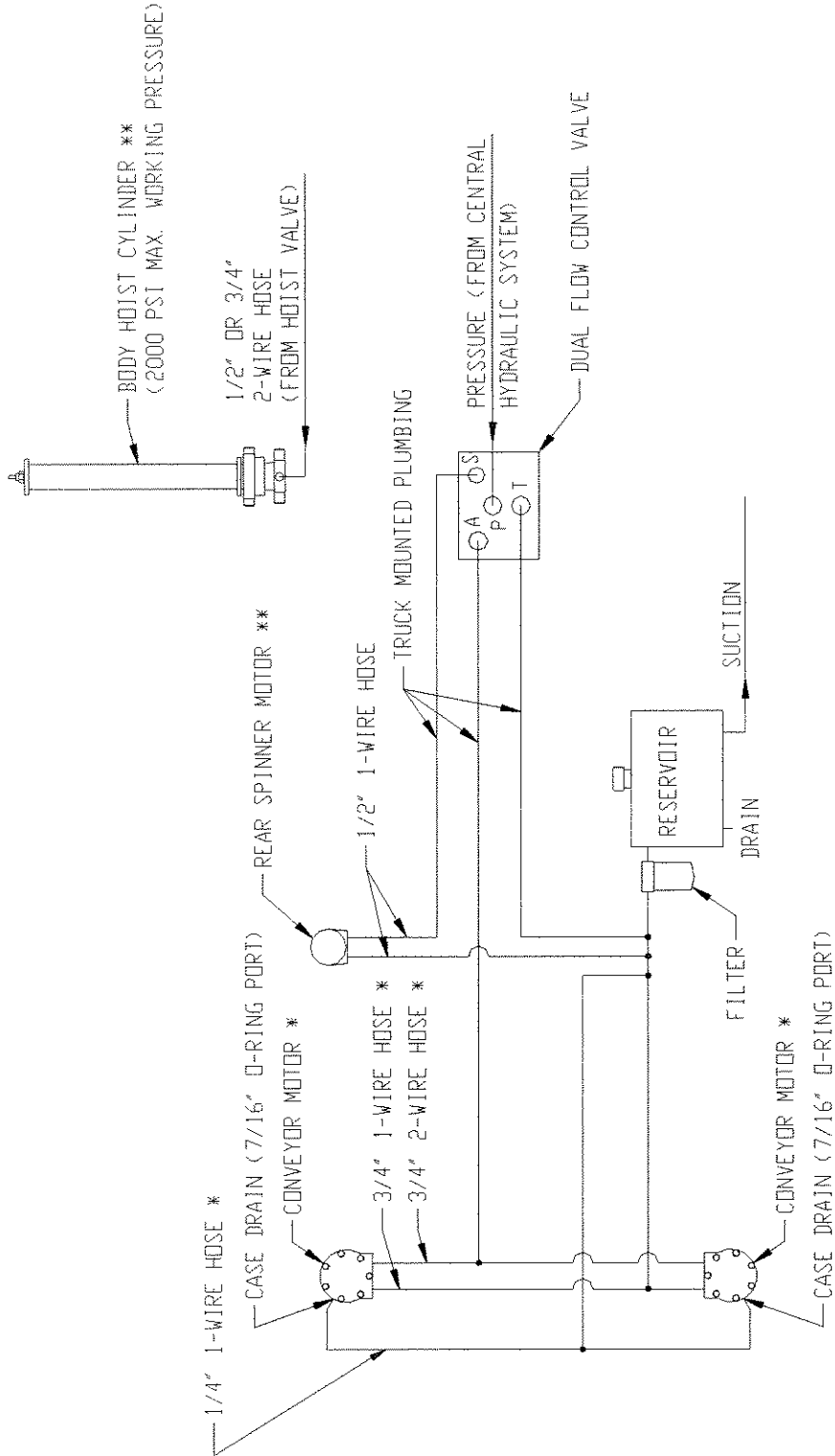

NOTES:

1. SPINNER SHOULD OPERATE IN COUNTER-CLOCKWISE DIRECTION AS VIEWED FROM TOP OF SPINNER
2. IF A MOTOR OPERATES IN THE WRONG DIRECTION, REVERSE HOSE CONNECTIONS AT MOTOR PORTS (USUALLY EASIER)

- * - APB BODY MOUNTED COMPONENTS
- ** - COMPONENTS FURNISHED WITH APB OPTIONS
- - UNLABELED COMPONENTS FURNISHED BY INSTALLER

**REAR DRIVE
DUAL MOTOR PLUMBING DIAGRAM**
(for bodies 12 ft. and over)

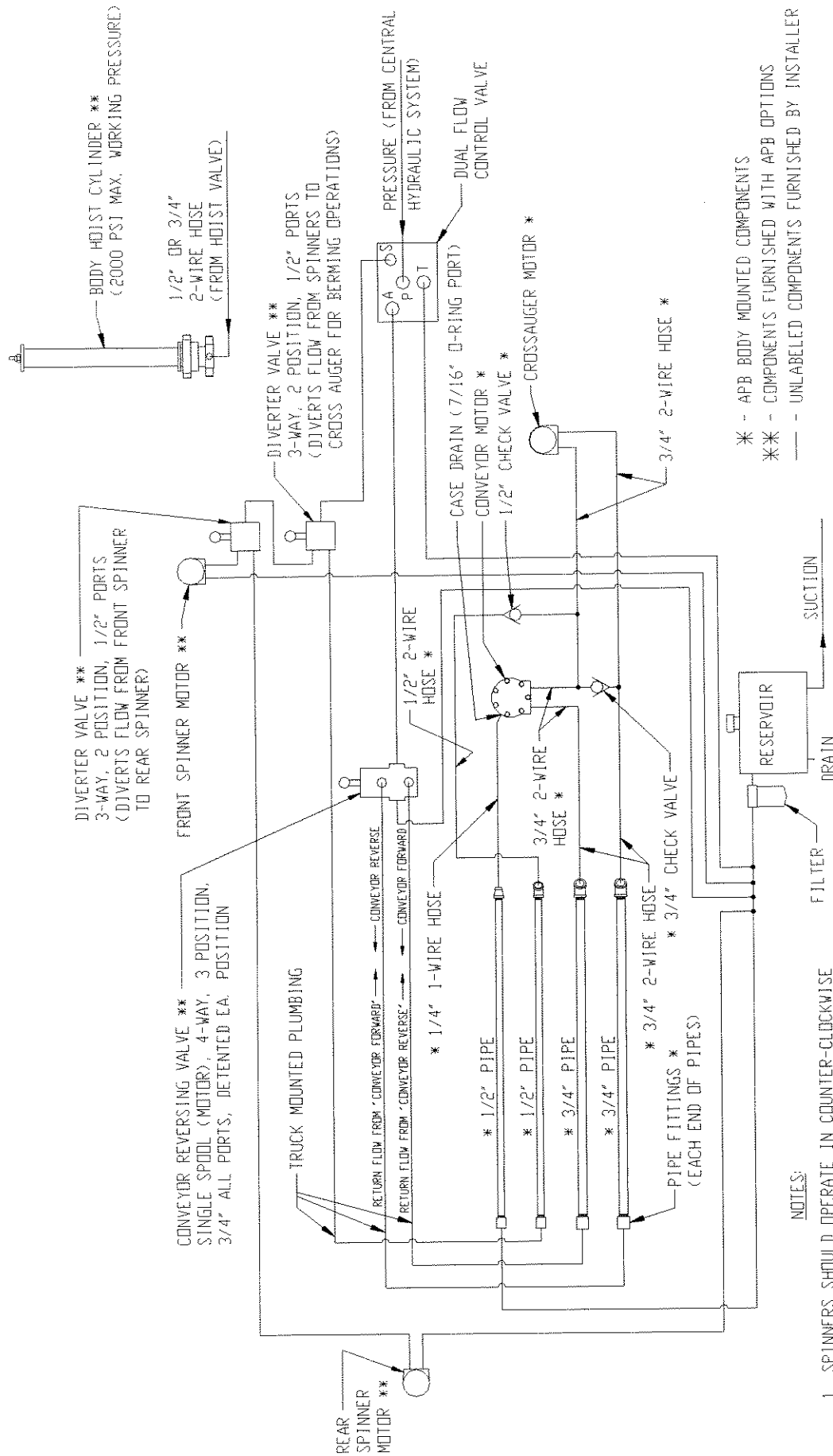

FRONT DRIVE
SINGLE MOTOR PLUMBING DIAGRAM
(FOR APB'S WITH BOTH FRONT & REAR SPINNERS)
(for bodies 11 ft. and under)

- * - APB BODY MOUNTED COMPONENTS
- ** - COMPONENTS FURNISHED WITH APB OPTIONS
- UNLABELED COMPONENTS FURNISHED BY INSTALLER

NOTES:

1. SPINNERS SHOULD OPERATE IN COUNTER-CLOCKWISE DIRECTION AS VIEWED FROM TOP OF SPINNERS
2. IF A MOTOR OPERATES IN THE WRONG DIRECTION, REVERSE HOSE CONNECTIONS AT MOTOR PORTS (USUALLY EASIER)

Z:\0013\39500A\FISHP01

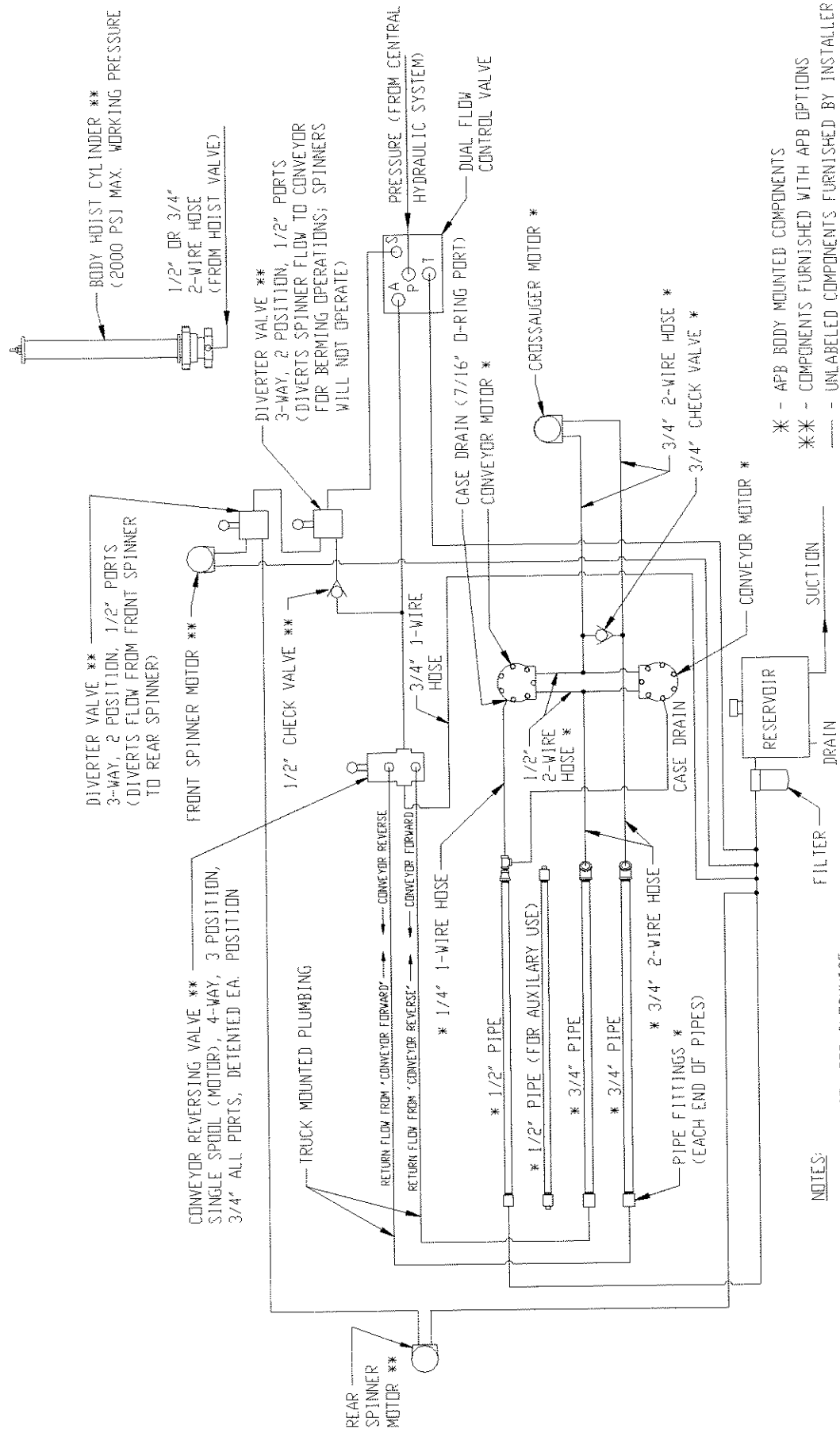

- * - APB BODY MOUNTED COMPONENTS
- ** - COMPONENTS FURNISHED WITH APB OPTIONS
- - UNLABELED COMPONENTS FURNISHED BY INSTALLER

**FRONT DRIVE
DUAL MOTOR PLUMBING DIAGRAM**
(FOR APB'S WITH BOTH FRONT & REAR SPINNERS)
(for bodies 12 ft. and over)

NOTES:

1. SPINNERS SHOULD OPERATE IN COUNTER-CLOCKWISE DIRECTION AS VIEWED FROM TOP OF SPINNERS
2. IF A MOTOR OPERATES IN THE WRONG DIRECTION, REVERSE HOSE CONNECTIONS AT MOTOR PORTS (USUALLY EASIER)

2A-00113-285001 (08M60)

MOUNTING BODY, HOIST AND PROP

⚠ DANGER! Observe all safety precautions during all installation procedures. Never be under or allow anyone else to be under a raised body without proper support.

INSTALLING BACK HINGE ON TRUCK FRAME

In order for body to raise and lower properly without placing undue stress on truck frame and body frame, it is necessary to pay particular attention to alignment and squareness of rear hinge on truck frame.

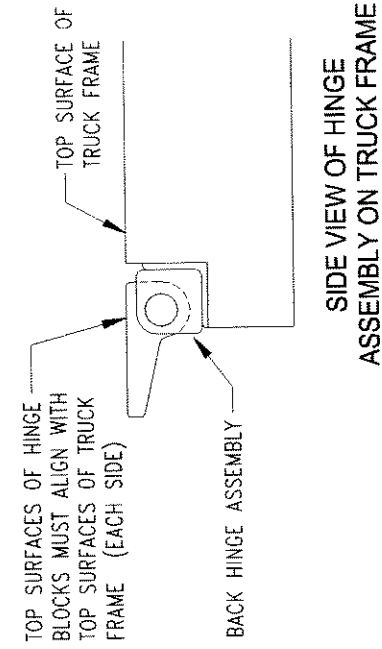

SIDE VIEW OF HINGE ASSEMBLY ON TRUCK FRAME

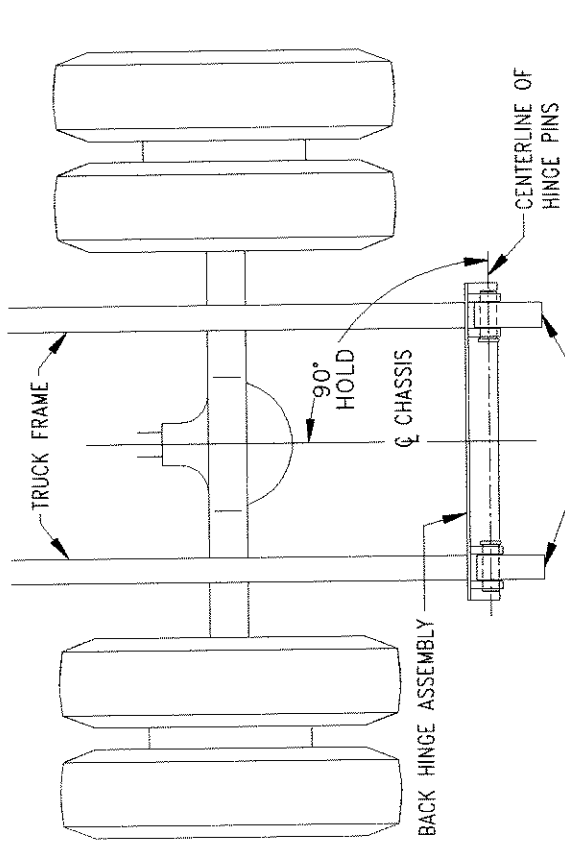

HINGE ASSEMBLY MUST BE POSITIONED SO HINGE BLOCKS ALIGN WITH TRUCK FRAME MEMBERS

TOP SURFACES OF HINGE BLOCKS MUST ALIGN WITH TOP SURFACES OF TRUCK FRAME (SEE SIDE VIEW ON THIS PAGE)

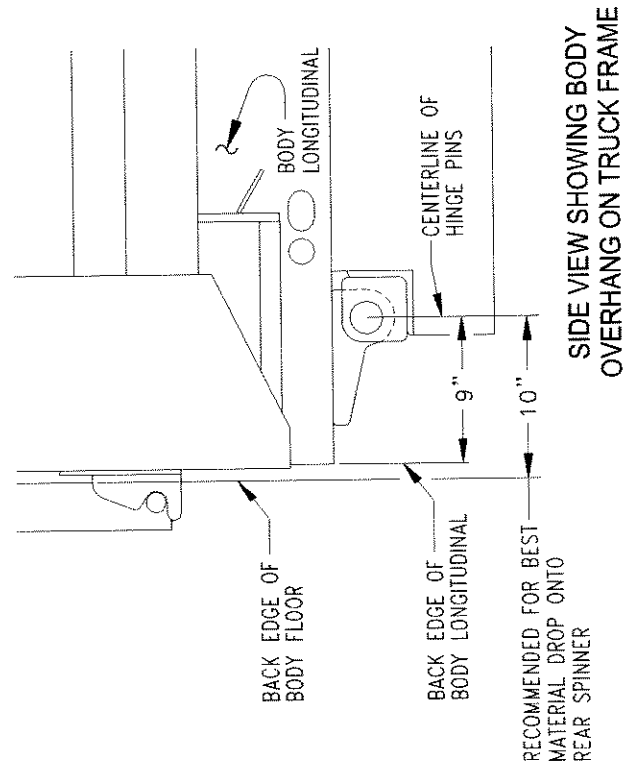

SIDE VIEW SHOWING BODY OVERHANG ON TRUCK FRAME

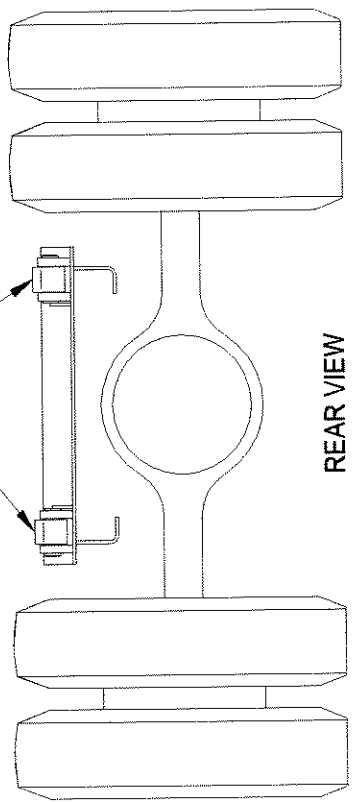

INSTALLING HOIST LIFT FRAME ON TRUCK FRAME

It is recommended that rear hinge and body be installed first in order for hoist lift frame to be located in best alignment with hoist mountings on front of body. See "SIDE VIEW" illustration below.

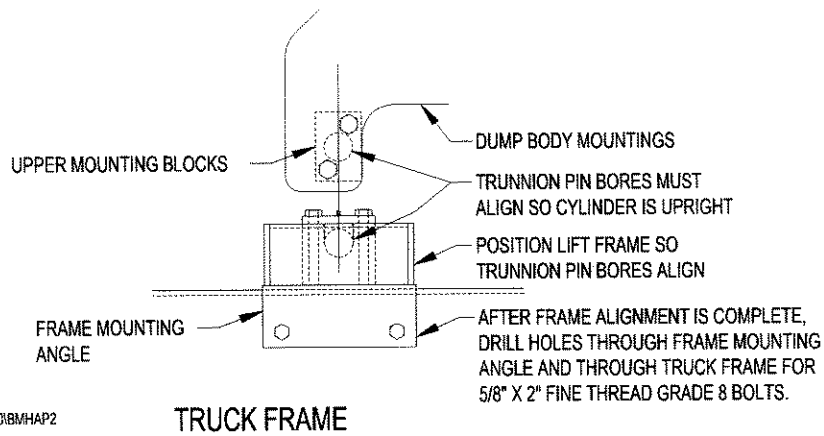
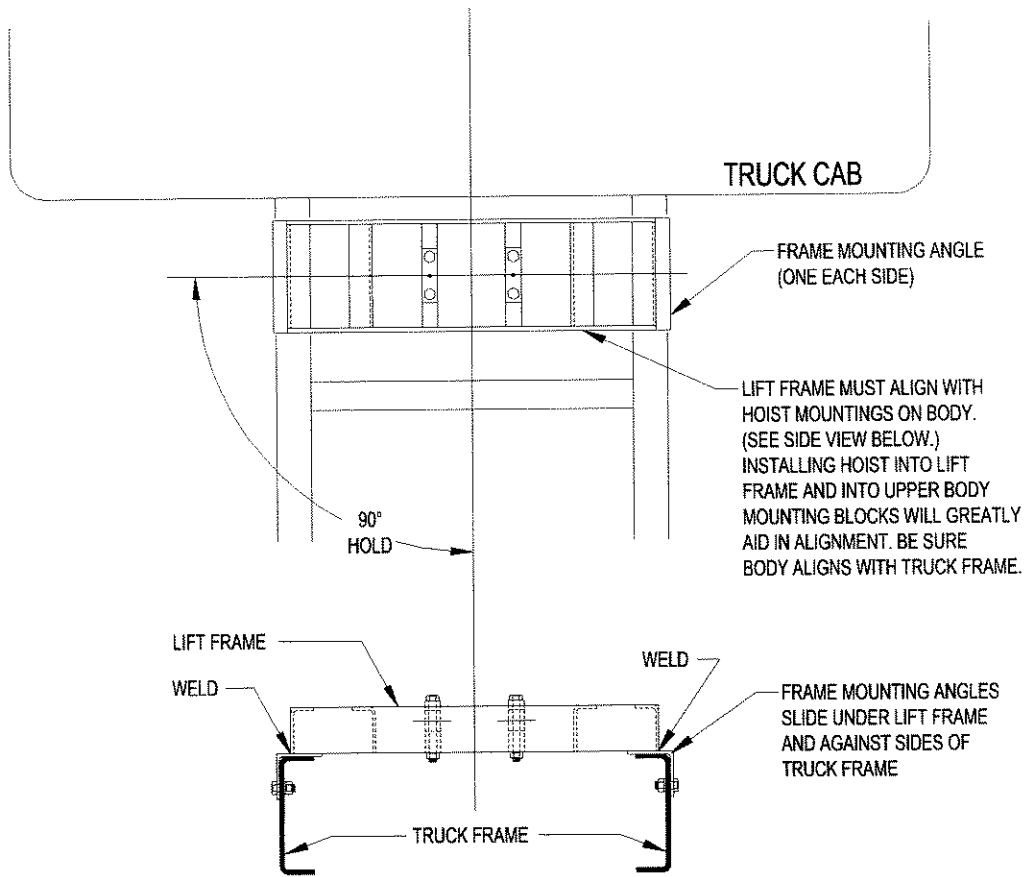

Z:100113:39500:BMHAP2

SIDE VIEW

INSTALLING AND OPERATING HOIST CYLINDER

(for cylinder maintenance see pages 31 & 32)

When installing cylinder, be sure cylinder is standing upright when fully retracted. Maximum initial force to raise body is achieved in this position. Some movement at the top of the cylinder can be expected and is acceptable. Raise body slowly and check to be sure outer protective cover does not contact base tube or outer tubes while extending.

Body guide bars are included in the hoist and body mounting parts package. Circumstances (such as longer bodies) on your installation may require the use of guide bars, however under normal conditions guide

bars are not recommended. Closely fitting guide bars prevent small amounts of side-to-side hoist cylinder movement. This in turn forces the outer protective cover against the base tube thus scratching it when cylinder extends.

For storage and shipping purposes, cylinders are lightly coated with oil as a moisture barrier. During first several strokes of cylinder this oil may be seen dripping from cylinder parts, but will cease as cylinder is used.

INSTALLING BODY PROP

DANGER!

To avoid serious injury, during all prop installation procedures when body is raised, body must be securely blocked at all times so it cannot come down. Support blocks must not be removed until there is no danger of anyone being under body when body is lowered.

After prop installation is complete, raise and lower body slowly to make sure prop functions properly as noted in illustration.

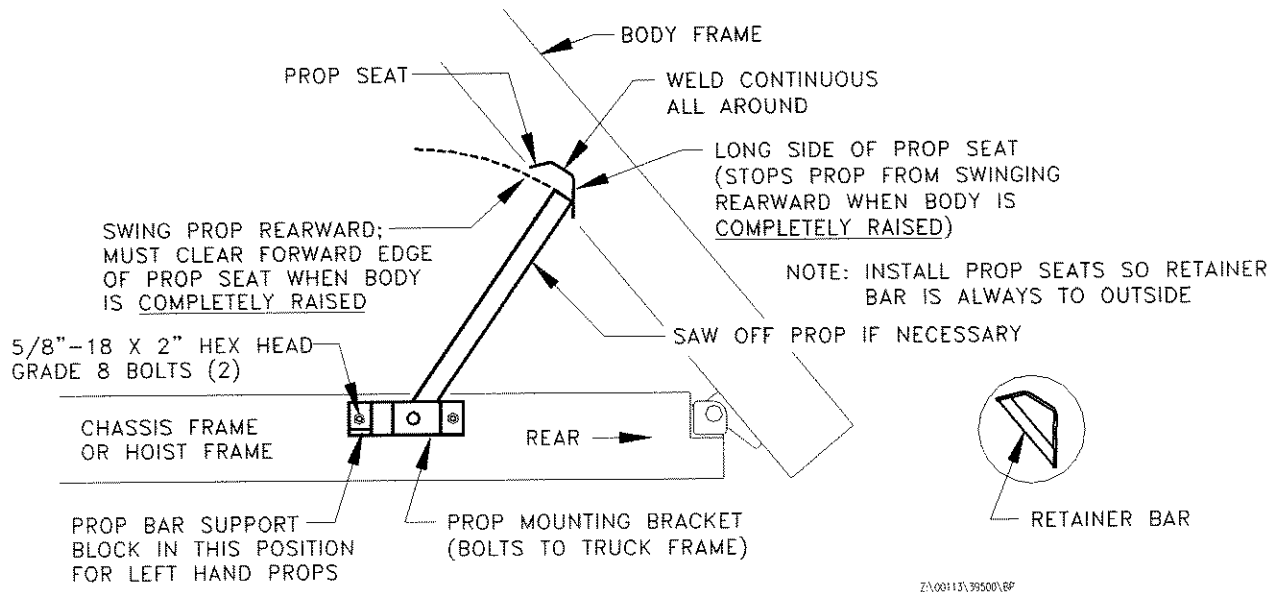

STANDARD LEFT HAND PROP INSTALLATION IS SHOWN, FOR RIGHT HAND INSTALLATION, USE RIGHT HAND PROP PARTS (IF FURNISHED). ABOVE INSTRUCTIONS STILL APPLY, BUT ARE OPPOSITE HAND.

INSTALLING FRONT SPINNER ASSEMBLY

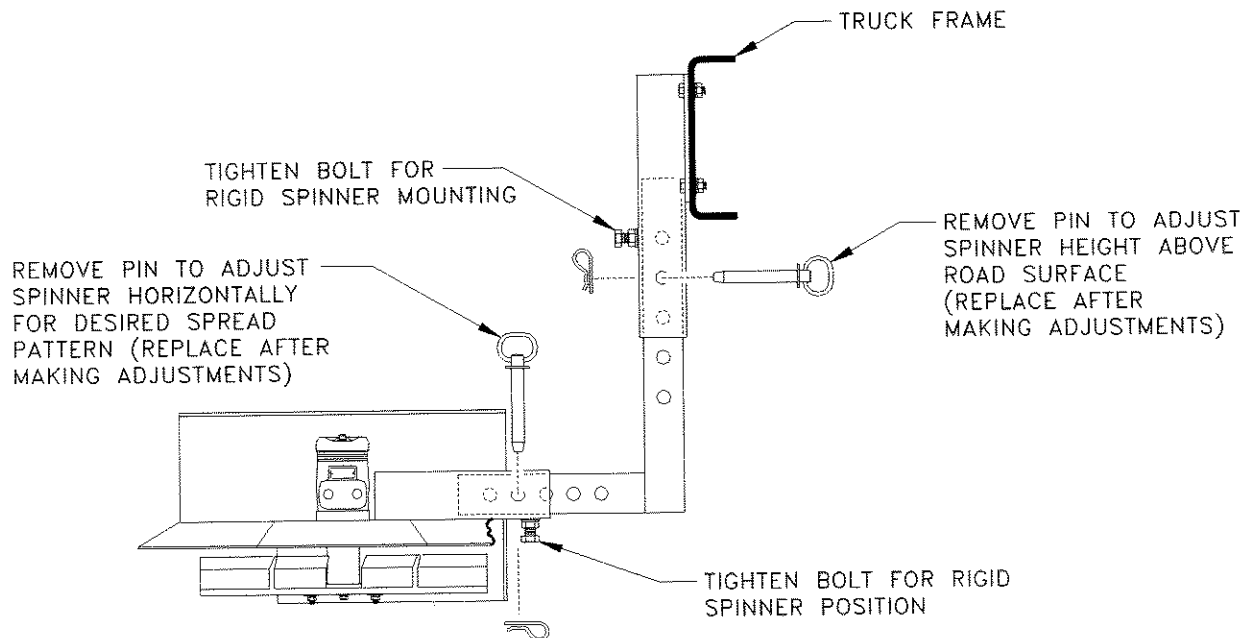
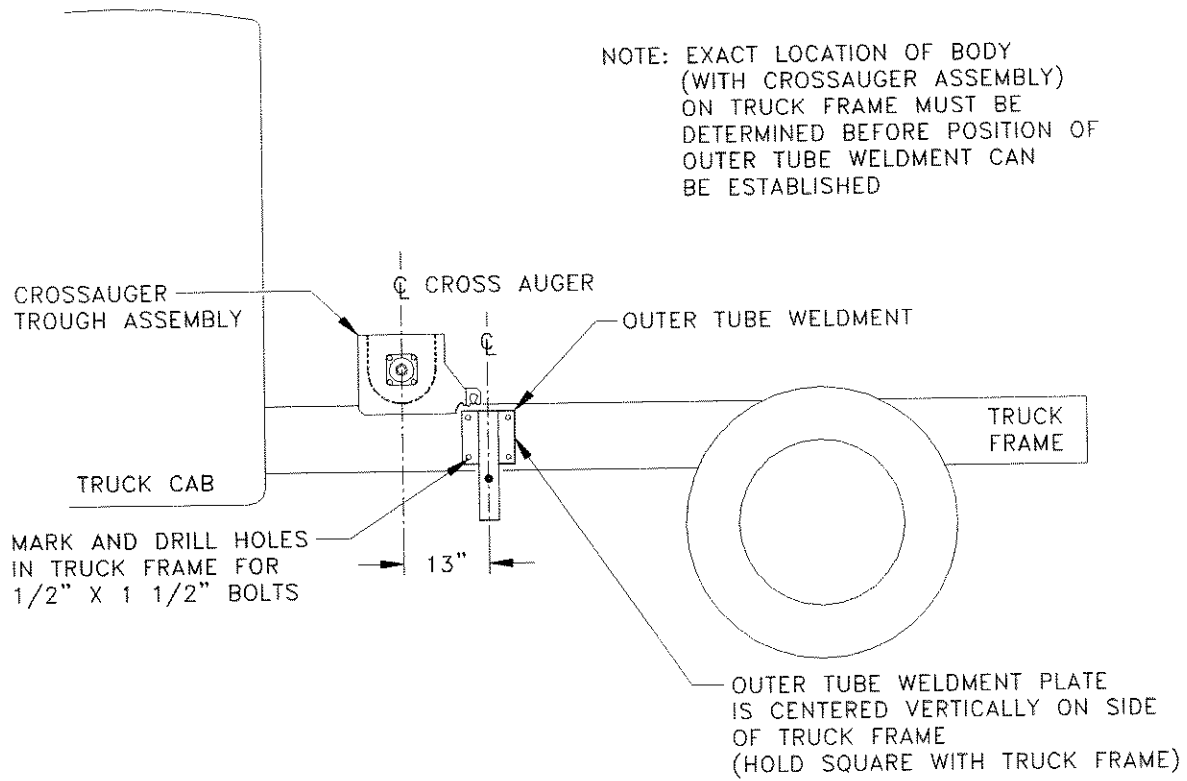

Z:\00113\39500\FSA.DWG

INSTALLING FRONT MATERIAL CHUTE AND ADJUSTING FRONT SPINNER ASSEMBLY

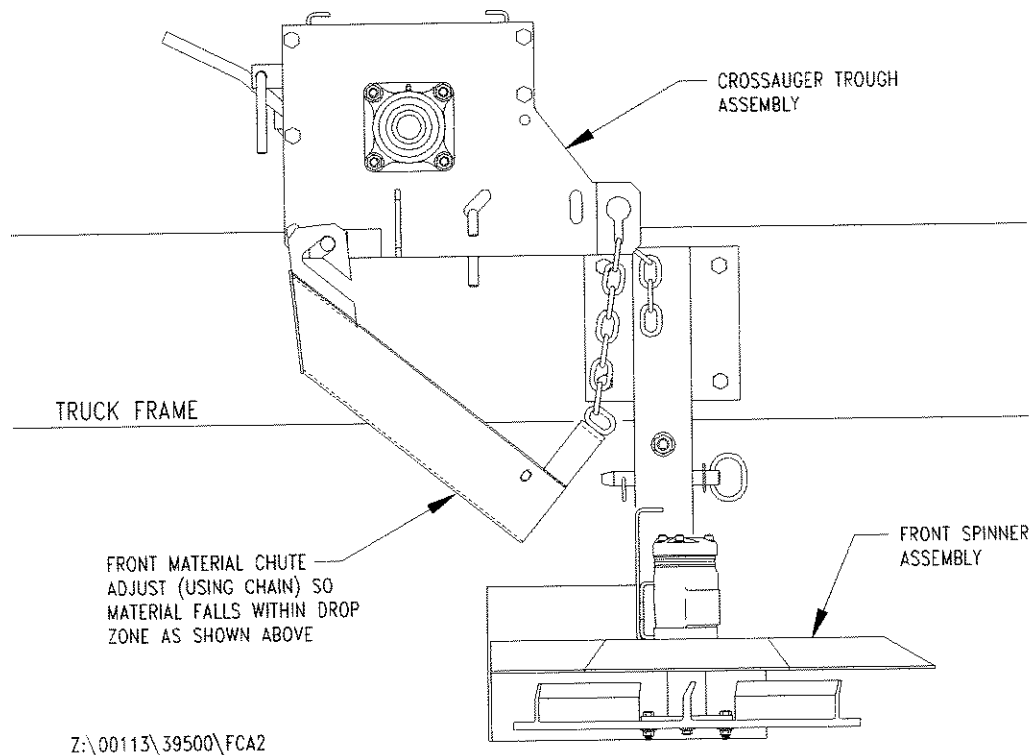
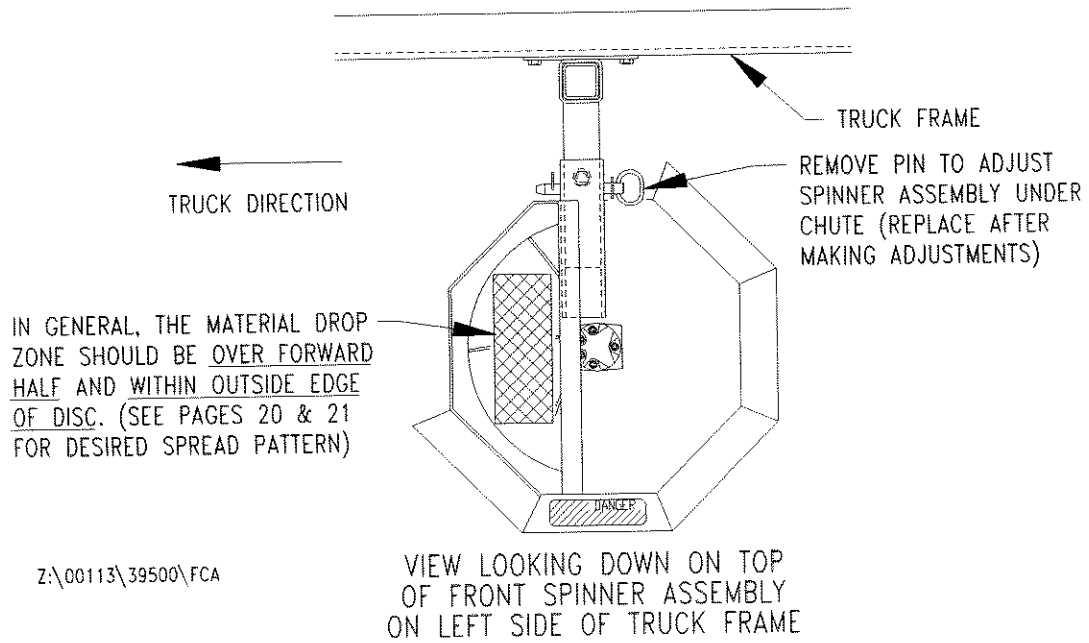

VIEW LOOKING TO LEFT SIDE OF TRUCK SHOWING MATERIAL CHUTE AND FRONT SPINNER ASSEMBLY IN PLACE

INSTALLING REAR SPINNER ASSEMBLY

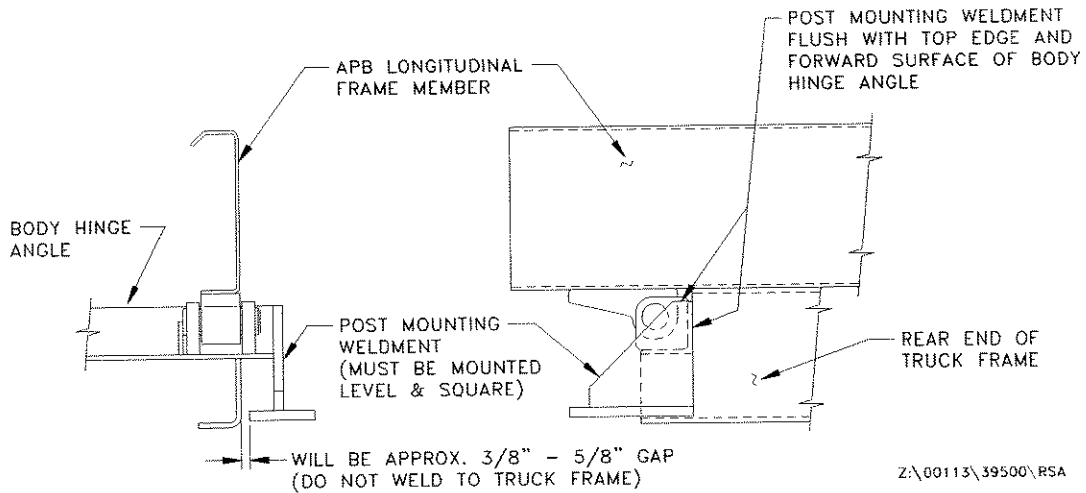

**VIEW LOOKING TO REAR
AND AT RIGHT SIDE OF
TRUCK FRAME**

**VIEW LOOKING TO RIGHT
SIDE AT REAR OF TRUCK
FRAME**

Z:\00113\39500\RSA

WELDING POST MOUNTING WELDMENT TO BODY HINGE ANGLE:

1. If desired, it may be easier to weld post mounting weldment to body hinge angle before body hinge angle is welded to truck frame. In this way, better welding may be accomplished due to easier welding positions.
2. Place continuous weld at all joints where post mounting weldment contacts end of body hinge angle.

ASSEMBLING POST WELDMENT TO MOUNTING BRACKET

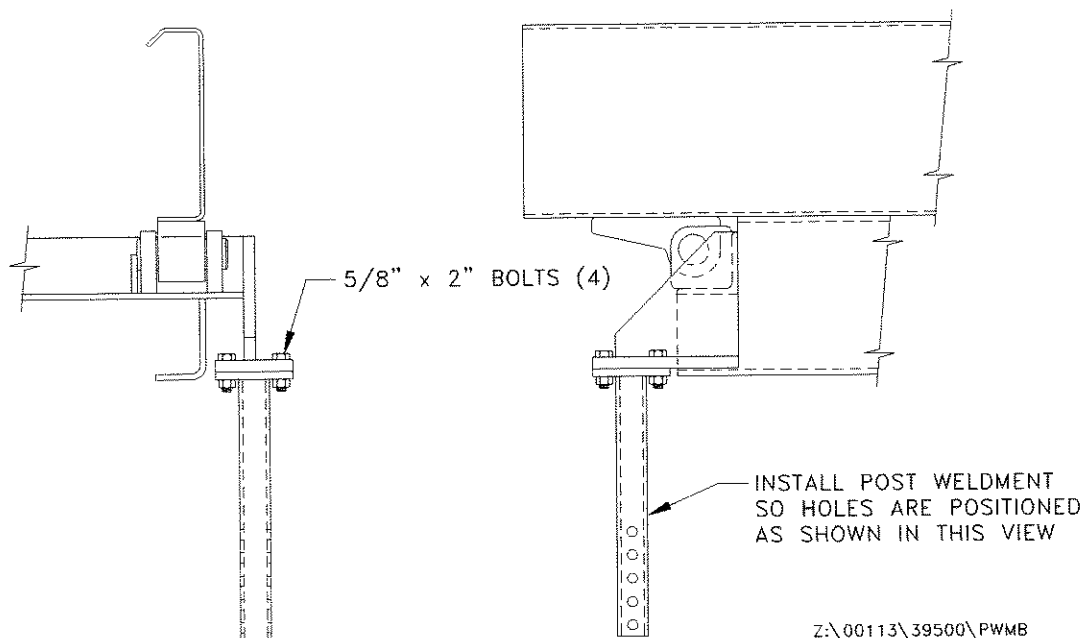

Z:\00113\39500\PWMB

VIEWS SAME AS ABOVE

INSTALLING HINGED REAR MATERIAL CHUTE ASSEMBLY AND ADJUSTING REAR SPINNER ASSEMBLY

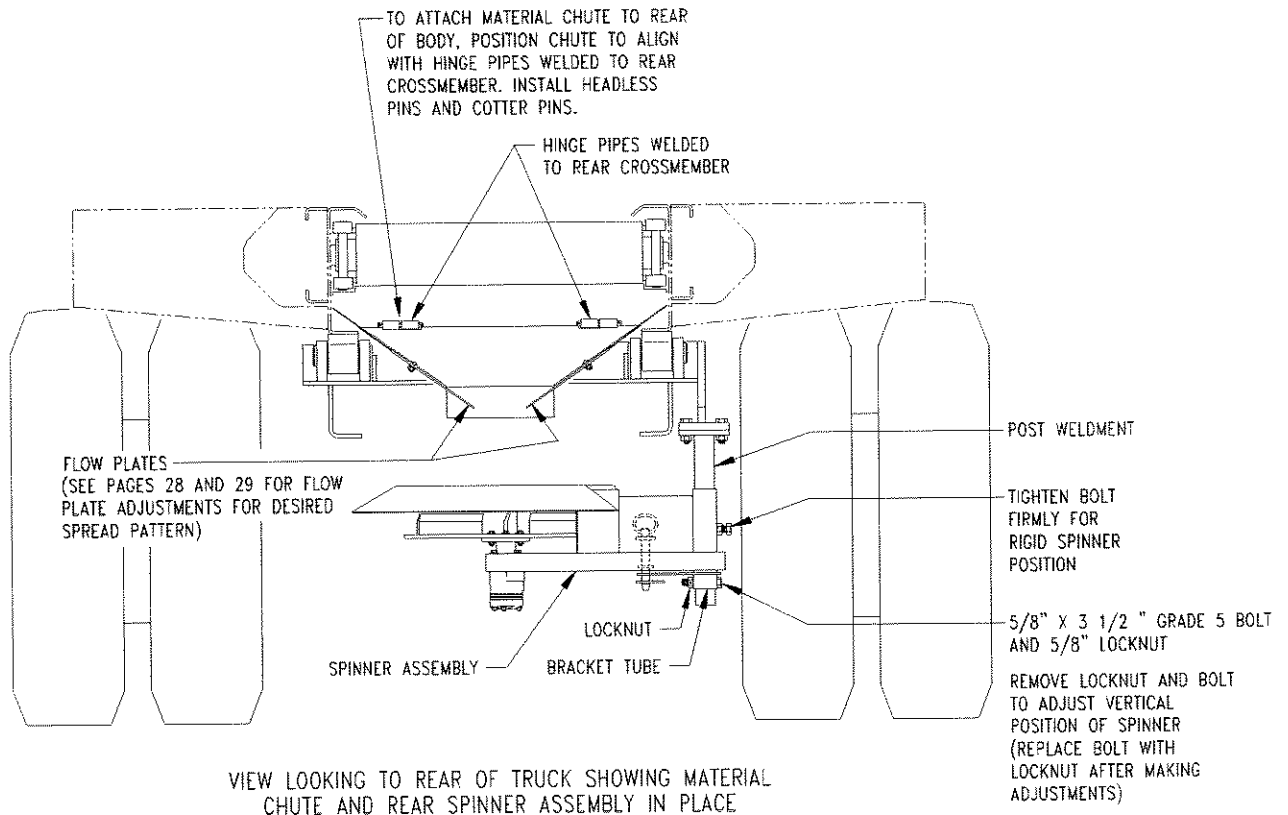

IMPORTANT !
LOCKNUT MUST BE TIGHTENED AGAINST BRACKET TUBE AT ALL TIMES

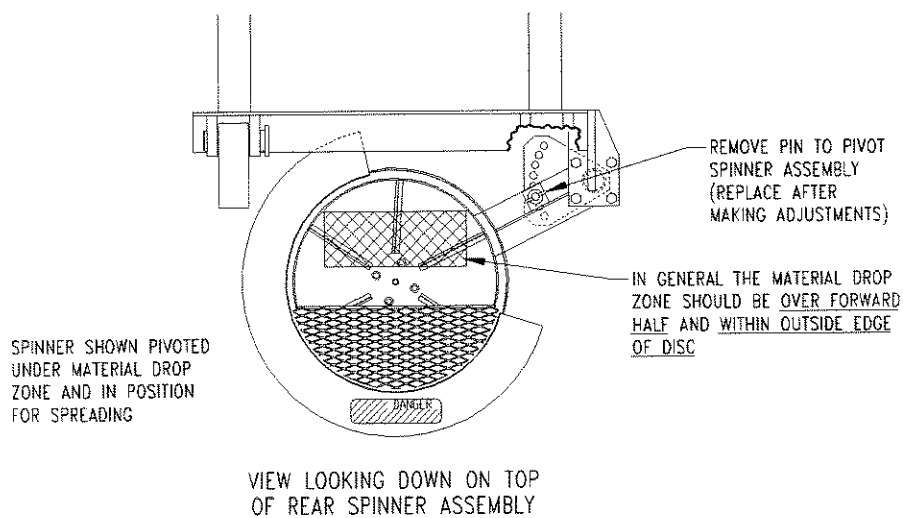

FULL LENGTH CONVEYOR COVER AND STUB CONVEYOR COVER INSTALLATION

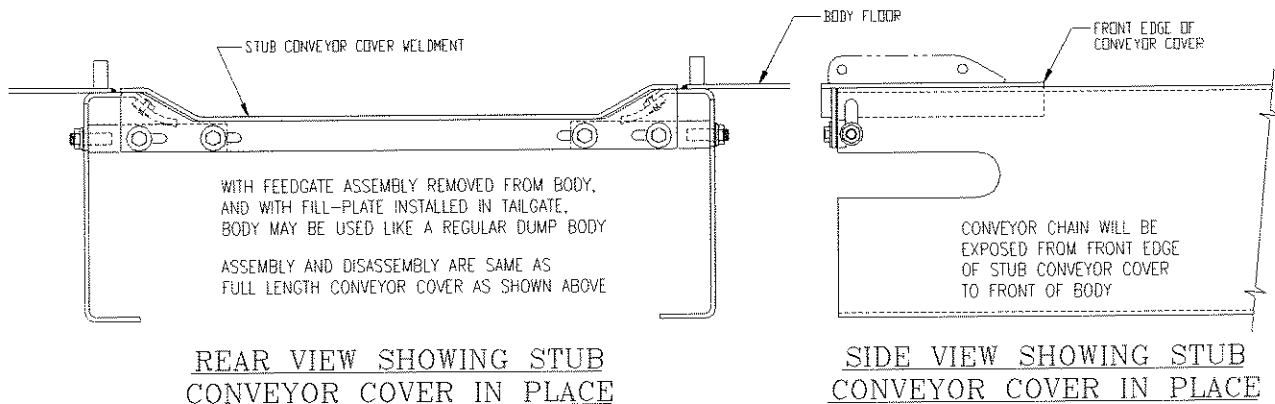
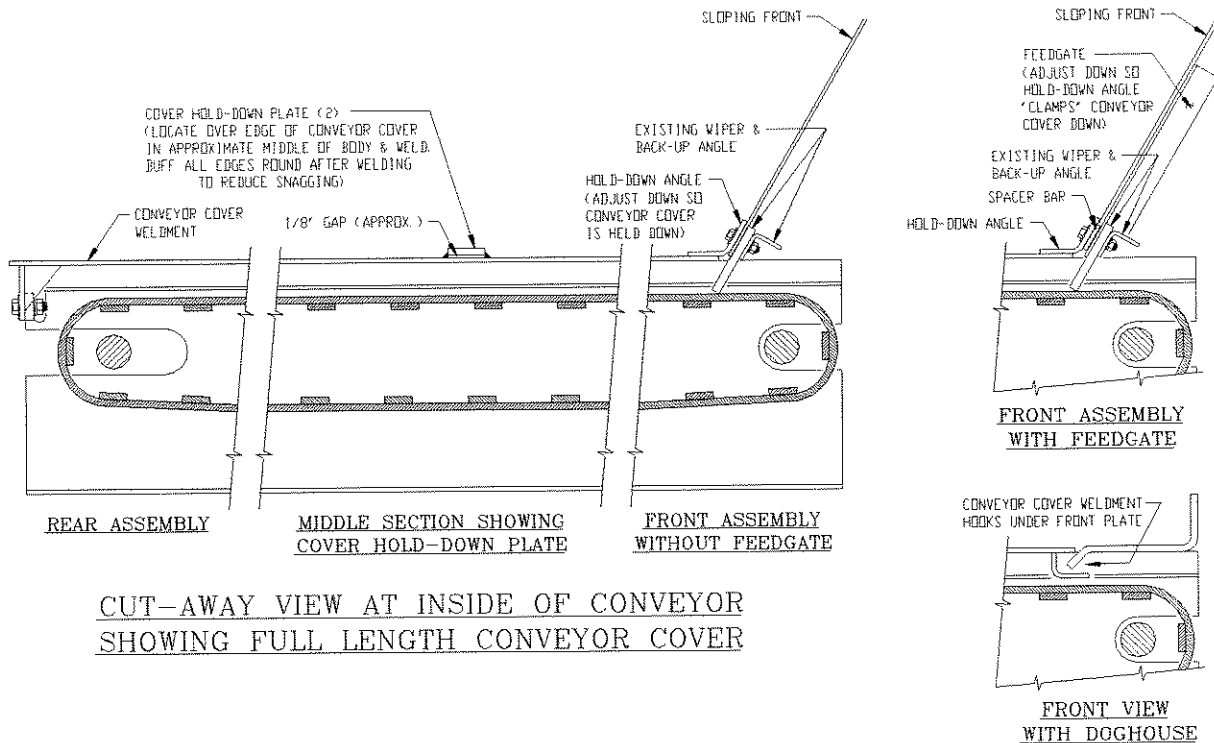
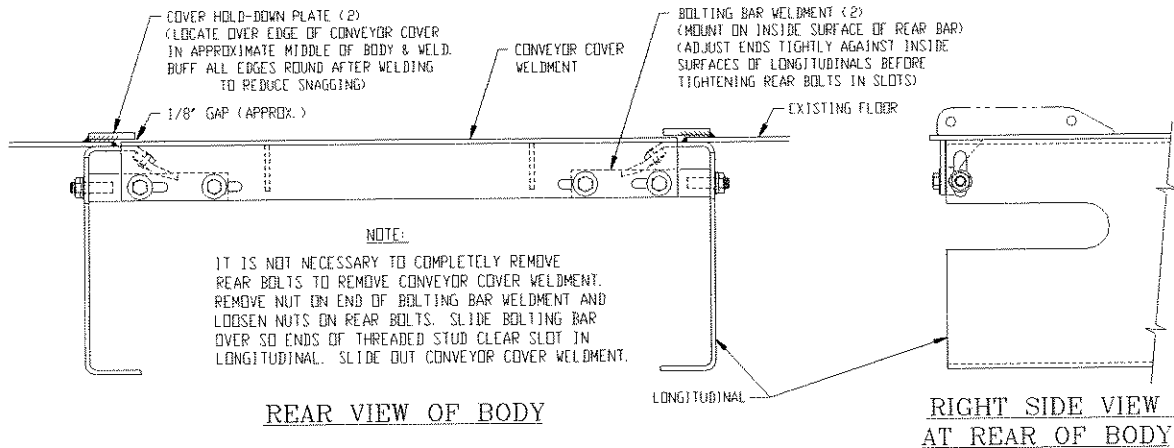

BODY OPERATING INSTRUCTIONS

Hydraulic Operating Instructions

DANGER!

1. When starting up new equipment, be sure everyone is standing clear; watch for anything that may require shutting system down.
2. Be sure lever on valve is moved completely to "OFF" position before working in or around spreading equipment.

Initial Start Up

1. Fill reservoir about three-fourths full with high grade non-foaming hydraulic oil. **KEEP OIL CLEAN!**
2. Move valve on-off lever of OFF position.
3. Open conveyor and spinner knobs on valve.
4. Engage PTO and allow hydraulic oil to circulate several minutes to warm up.
5. Move valve on-off lever to ON position.
6. Check entire hydraulic system for leaks.
7. Examine conveyor and spinner to see if they are turning in proper direction.
Note: If your unit is equipped with a valve for reversing the conveyor direction, it will be necessary to note the direction of conveyor travel when the reversing valve handle is moved to either of the operational positions.
8. Open and close conveyor and spinner speed control knobs at various settings and check to see that conveyor and spinner speeds increase and decrease corresponding with knob settings.
9. Refill reservoir to three-fourths full.
10. Hydraulic system is ready for use.

Spreader Operation

1. Start truck engine and allow hydraulic system to warm up by shutting off spinner and conveyor knobs and moving on-off lever to ON position.

2. Turning the spinner knob counter clockwise will increase the spinner speed and width of spread.
3. Turning the conveyor knob counter clockwise will increase the conveyor speed and thus the amount of material spread.
4. The feed gate at the front (or rear) of the body will also allow more material to feed to the front (or rear) mounted spinner when opened wider. Refer to pages 26 thru 29 for spinner adjustment.
5. The control valve may be turned on and off, or adjusted while truck is in motion.
6. Spinner and conveyor may be stopped at the same time without changing their valve settings by moving the on-off lever to OFF position.

The conveyor built into the floor of your unit is used to convey materials to front and/or rear feed gate openings. The conveyor on/off is controlled from the cab, and the direction of conveyor travel is controlled by a separate valve from either inside the cab or outside the cab depending upon your particular hydraulic installation.

The crossauger is sized to carry away all material delivered by floor conveyor up to 6" gate height. If unit is to be used for berming operations with gate fully opened to 8", it will be necessary to divert spinner hydraulic oil flow to the **input port** of the crossauger drive motor, thus increasing crossauger drive motor speed. In the operating mode, completely opening both conveyor and spinner knobs on dual flow control valve will operate both floor conveyor and crossauger at maximum speeds. Refer to pages 6,7,8,11 and 12 for explanation and hydraulic plumbing diagram.

If your dump body is equipped with a feedgate at the front, then it is also equipped with a crossauger conveyor. Turning feedgate adjusting crank and observing gate height ruler will allow material to be metered into crossauger trough and conveyed to opening.

If your dump body is not equipped with a feedgate at the front, then it is intended to discharge to the rear only, in which case a conveyor reversing valve is not necessary.

HAULING, DUMPING AND CONVEYING

General Hauling:

Your all purpose dump body may be used for hauling nearly all materials that are commonly hauled in ordinary dump bodies. Since your unit is equipped with a conveying system which has been built into the floor, care must be exercised to avoid damage to its parts. A conveyor cover is available for protecting the conveyor while body is used for general hauling.

Handle on left front corner of body is used to latch and unlatch tailgate for high volume dumping. Use spreader chains for adjusting tailgate opening.

The tailgate can also be laid down using spreader chains to support in a level position. If your dump body is equipped with a tailgate having a revolving style feedgate, refer to page 23 for using and converting the revolving feedgate. If your dump body is equipped with a sliding style feedgate, refer to pages 24 and 25 for using the sliding feedgate and fillplate.

For high volume dumping without raising body, tailgate may be unlatched and conveyor operated rearward. Bulk of material will be unloaded, then remaining material can be discharged by raising body.

Dumping rock larger than 2" directly onto **unprotected** conveyor flite bars or conveyor belt and seal strips is not recommended. Bending of bars or gouging of belt and seal strips will result.

Notice: Visible dents on body and conveyor floors, bent conveyor flite bars, and gouged conveyor belting and seal strips indicate that materials larger than those recommended have been dropped into the body, and thus will void all warranties.

Hauling materials for ice and snow control operations:

Your all purpose dump body may be used for hauling all materials that are commonly used for spreading on road surfaces for ice and snow control operations. These will include salt and various abrasives, and mixtures consisting of various materials.

Materials should be relatively free flowing, and be free of anything larger than 3/4" chunks which will not crumble or otherwise be broken up while being conveyed. Larger materials will lodge in opening of low feedgate settings and disrupt set spread rates. Larger materials may also jam and stop front crossauger operation and/or damage crossauger conveyor parts.

Hauling Materials For Berming Operations:

Your all purpose dump body may be used for berming operations if it has been equipped with a cross auger conveyor at front of body. Aggregate materials should not exceed 3/4" in size, should be relatively free flowing, and be free of anything larger than 3/4" particles which will not crumble or otherwise be broken up while being conveyed. Larger materials may jam and stop auger operation and/or damage cross auger conveyor parts. Aggregate materials which are not comprised of at least 50% fines should not exceed 3/8" in particle size.

Hauling Asphalt:

Your all purpose dump body may be used for hauling all asphalt related materials that are commonly used in the pavement construction and patching industry. All body components including rubber belting, rubber seal strips and rubber wipers will withstand 350 ° F hot asphalt. An available asphalt lip must be installed if unit is to be used for dumping into paving equipment.

Note: If your unit has been purchased with a front crossauger conveyor, be sure front feedgate is closed down tightly so asphalt cannot enter crossauger trough. Solidified asphalt in trough will prevent auger from operating when needed.

For high volume dumping of asphalt, such as into paving equipment, tailgate may be unlatched and conveyor operated rearward. Bulk of load can be emptied before body is raised. For pothole patching, rear feedgate may be opened and conveyor operated rearward as desired.

Note: If not furnished with unit, a kit is available for installation which allows user to operate conveyor from rear of truck without going back to cab each time.

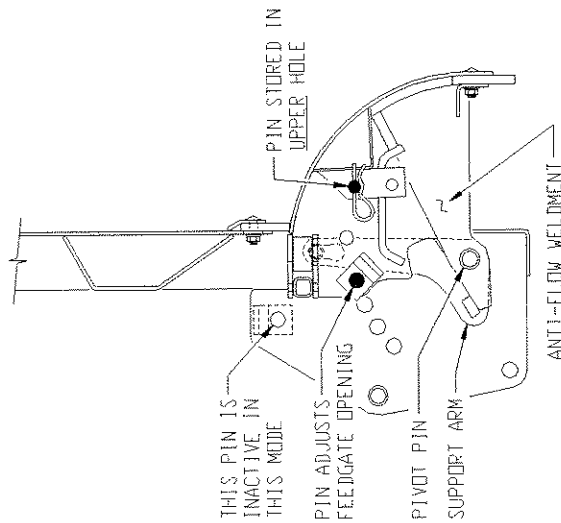

SPREADING

PIN IS STORED IN UPPER HOLE SO ANTI-FLOW WELDMENT WILL REMAIN IN DOWN POSITION WHEN FEEDGATE IS ROTATED UP FOR METERED CONVEYING OF MATERIALS DURING SPREADING OPERATIONS.

END VIEWS SHOW FEEDGATE ASSEMBLED IN TAILGATE

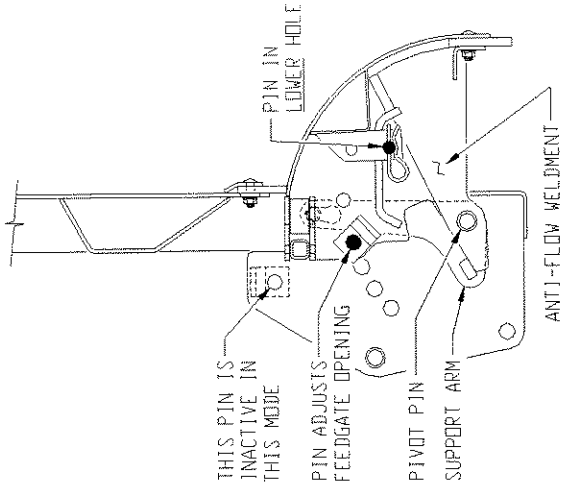

OCCASIONAL DUMPING

PIN IS PLACED IN LOWER HOLE SO ANTI-FLOW WELDMENT WILL BE SECURED WITH THE FEEDGATE WHEN THE TAILGATE IS OPENED FOR DUMPING OPERATIONS.

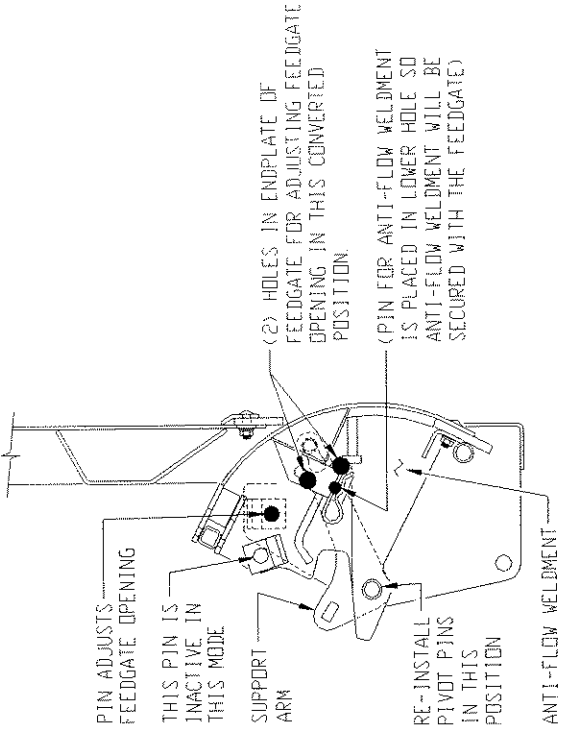

FEEDGATE IN CONVERTED POSITION FOR CONTINUOUS DUMPING, OR FOR DUMPING/SHOVELING THROUGH FEEDGATE OPENING

OPENING IN TAILGATE IS CLOSED OFF BY REMOVING PIVOT PINS AND CONVERTING FEEDGATE TO POSITION SHOWN.
 SUPPORT ARMS WILL ALLOW FEEDGATE TO BE CONVERTED TO NEW POSITION WHILE KEEPING FEEDGATE FROM FALLING.
 FEEDGATE CAN THEN BE ADJUSTED IN (2) POSITIONS FOR DUMPING OR SHOVELING THROUGH FEEDGATE OPENING.
 FEEDGATE ASSEMBLY CAN ALSO BE REMOVED (OR INSTALLED) WITHOUT THE USE OF TOOLS DO TO THE BANJO EYE SLOTS IN SUPPORT ARMS.

USING AND CONVERTING REVOLVING FEEDGATE IN TAILGATE

USING THE SLIDING FEEDGATE AND FILLPLATE

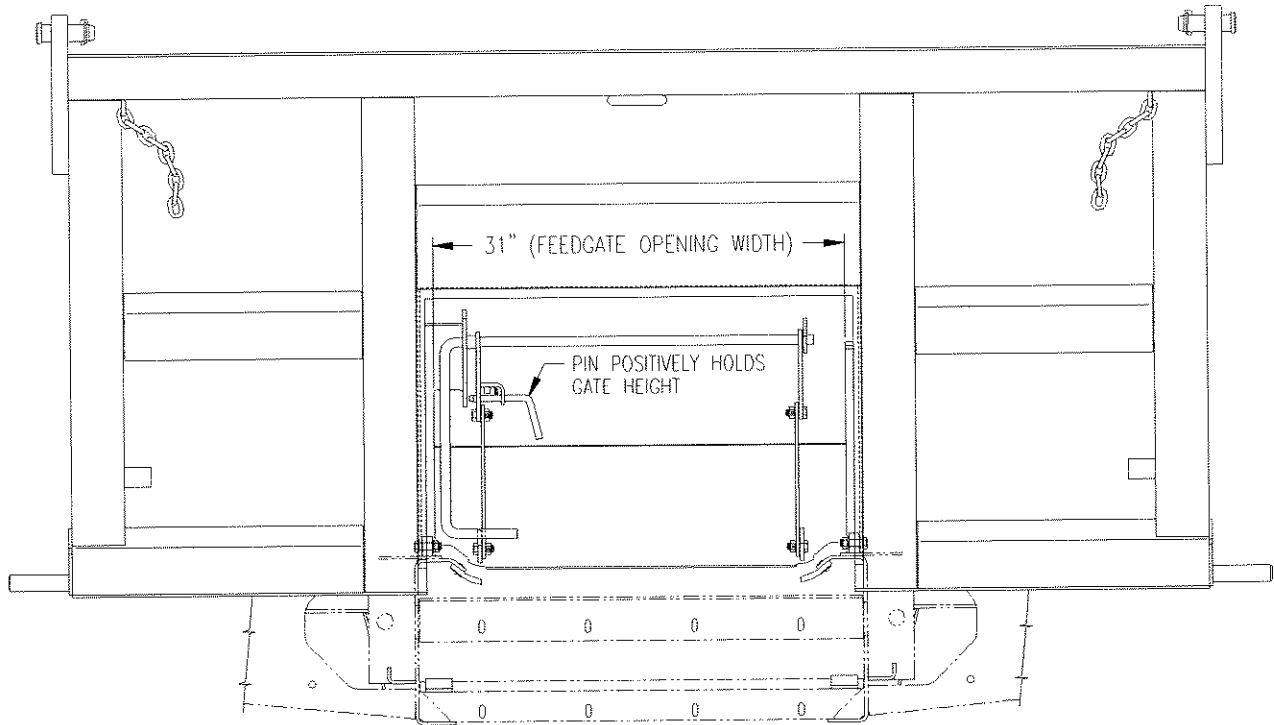

TAILGATE WITH SLIDING FEEDGATE INSTALLED
(FEEDGATE IS SHOWN SLIGHTLY OPEN)

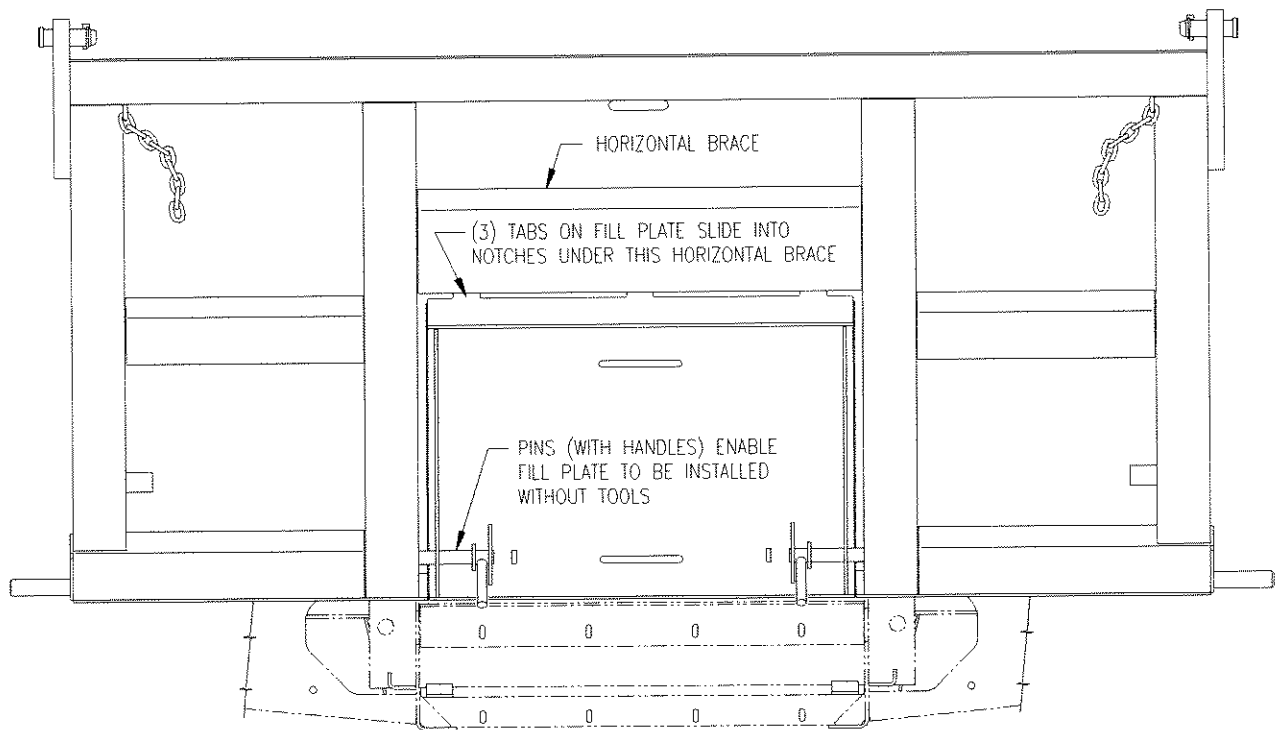

TAILGATE WITH FILL-PLATE INSTALLED
(INSIDE SURFACE OF TAILGATE IS SMOOTH WITH NO PROTRUSIONS)

USING THE SLIDING FEEDGATE AND FILLPLATE (CONTINUED)

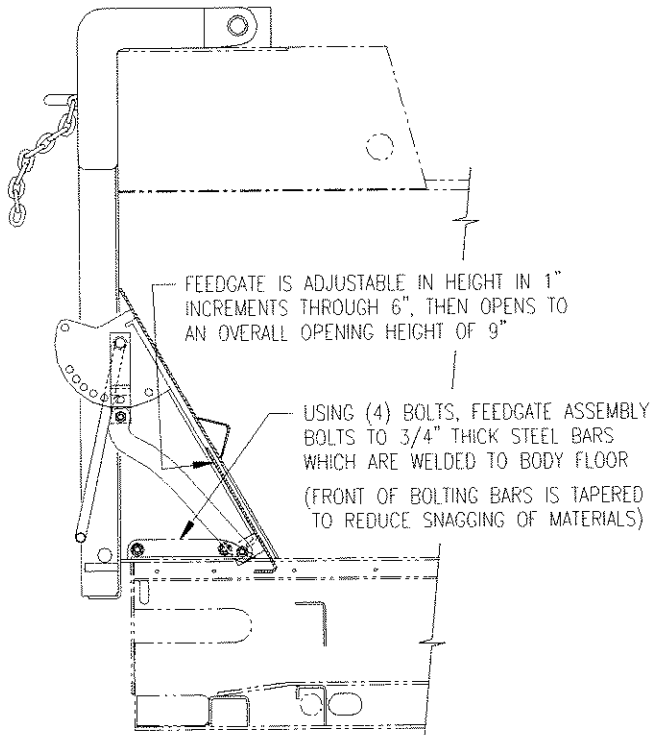

FEEDGATE IS ADJUSTABLE IN HEIGHT IN 1" INCREMENTS THROUGH 6", THEN OPENS TO AN OVERALL OPENING HEIGHT OF 9"

USING (4) BOLTS, FEEDGATE ASSEMBLY BOLTS TO 3/4" THICK STEEL BARS WHICH ARE WELDED TO BODY FLOOR (FRONT OF BOLTING BARS IS TAPERED TO REDUCE SNAGGING OF MATERIALS)

SIDE VIEW SHOWING FEEDGATE ASSEMBLY IN PLACE WITH TAILGATE CLOSED

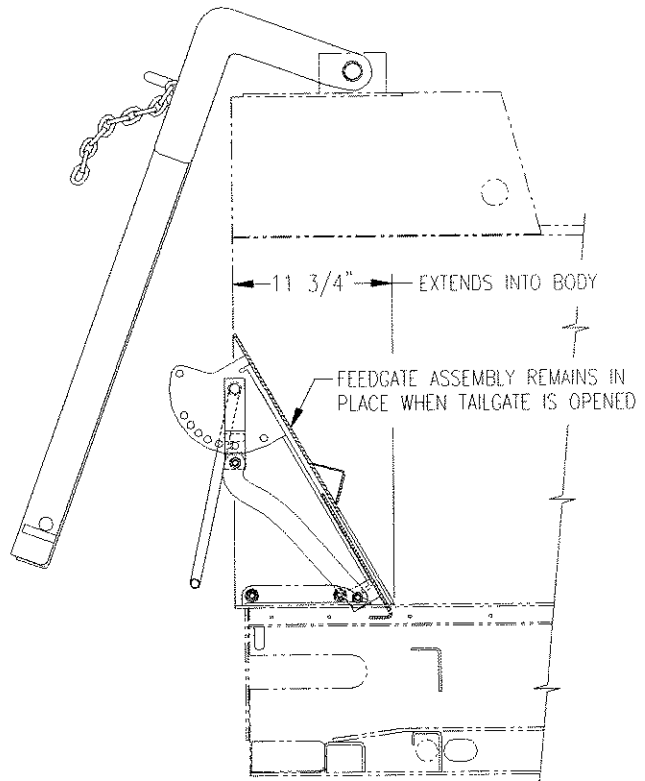

11 3/4" EXTENDS INTO BODY

FEEDGATE ASSEMBLY REMAINS IN PLACE WHEN TAILGATE IS OPENED

SIDE VIEW SHOWING FEEDGATE ASSEMBLY IN PLACE WITH TAILGATE OPENED

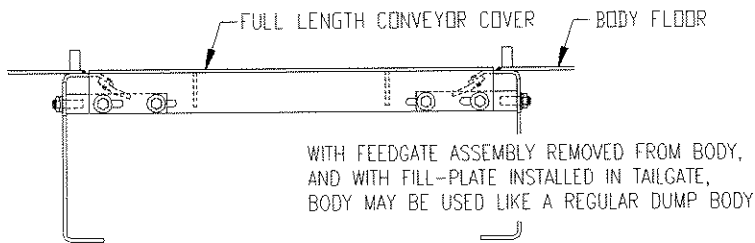

FULL LENGTH CONVEYOR COVER

BODY FLOOR

WITH FEEDGATE ASSEMBLY REMOVED FROM BODY, AND WITH FILL-PLATE INSTALLED IN TAILGATE, BODY MAY BE USED LIKE A REGULAR DUMP BODY

REAR VIEW SHOWING FULL LENGTH CONVEYOR COVER IN PLACE

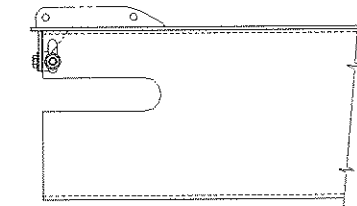

SIDE VIEW SHOWING FULL LENGTH CONVEYOR COVER IN PLACE

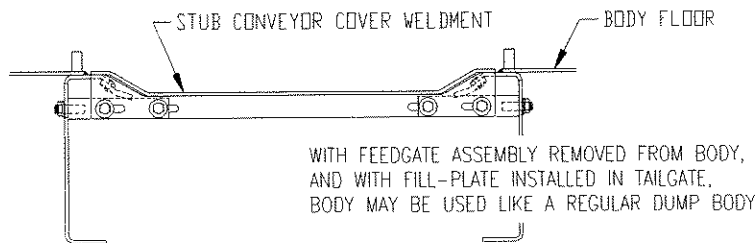

STUB CONVEYOR COVER WELDMENT

BODY FLOOR

WITH FEEDGATE ASSEMBLY REMOVED FROM BODY, AND WITH FILL-PLATE INSTALLED IN TAILGATE, BODY MAY BE USED LIKE A REGULAR DUMP BODY

REAR VIEW SHOWING STUB CONVEYOR COVER IN PLACE

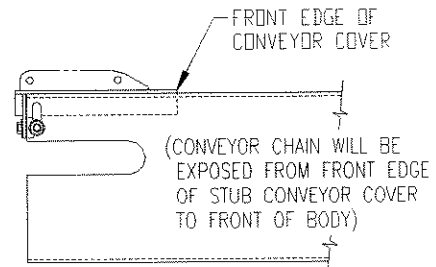

FRONT EDGE OF CONVEYOR COVER

(CONVEYOR CHAIN WILL BE EXPOSED FROM FRONT EDGE OF STUB CONVEYOR COVER TO FRONT OF BODY)

SIDE VIEW SHOWING STUB CONVEYOR COVER IN PLACE

NOTE: UNLESS OTHERWISE REQUESTED, SLIDING FEEDGATE ASSEMBLY, TAILGATE OPENING FILL-PLATE, AND STUB CONVEYOR COVER ARE FURNISHED AS STANDARD WITH ALL APB'S. (FULL LENGTH CONVEYOR COVER IS OPTIONAL)

ADJUSTING FRONT AND REAR SPINNERS FOR DESIRED SPREAD PATTERNS

⚠ DANGER!

Serious personal injury can result from being caught in a turning spinner. Stay clear and keep all others clear when spinner is turning.

Serious personal injury can result if hit by flying particles being thrown by a turning spinner.

Stand back, and keep all others back at least 50 feet while spinner is turning. DO NOT ASSUME that particles cannot be thrown by a turning spinner just because material is not being dropped onto the spinner; particles that have been sticking to the spinner may suddenly come loose and be thrown causing possible injury.

In general, for the most commonly desired spread patterns, the material drop zone should be **over forward half** and **within outside edge of disk**. See pages 17 & 19. Adjusting the specific location where material falls on the forward half of the spinner disk is very important. This allows the greatest portion of the material to be placed on the road surface in the three most commonly desired locations:
1. To the left of the vehicle
2. To the left rear of the vehicle
3. To the rear of the vehicle.

The primary spinner shield which is positioned approximately at the right forward quadrant of the spinner disk, is intended to restrict "stray" material to the spinner area and to aid in a more defined spread pattern.

Once the desired spread pattern has been obtained, increasing the spinner speed by opening the spinner control knob will give a wider spread pattern and closing the spinner control knob will give a narrower spread pattern.

Also, raising the spinner assembly higher above the road surface will give a wider spread pattern, and lowering the spinner assembly closer to the road surface will give a narrower spread pattern.

Note: *Allowing material to drop on a random more centered location on the spinner disk is not recommended. In so doing the material has no specific direction in which it can exit the spinner flites. As a result, material is distributed 360° around the spinner disk causing material to be spread in undesirable locations such as on rear truck chassis parts and in roadside ditches.*

ADJUSTING FRONT SPINNER FOR DESIRED SPREAD PATTERN

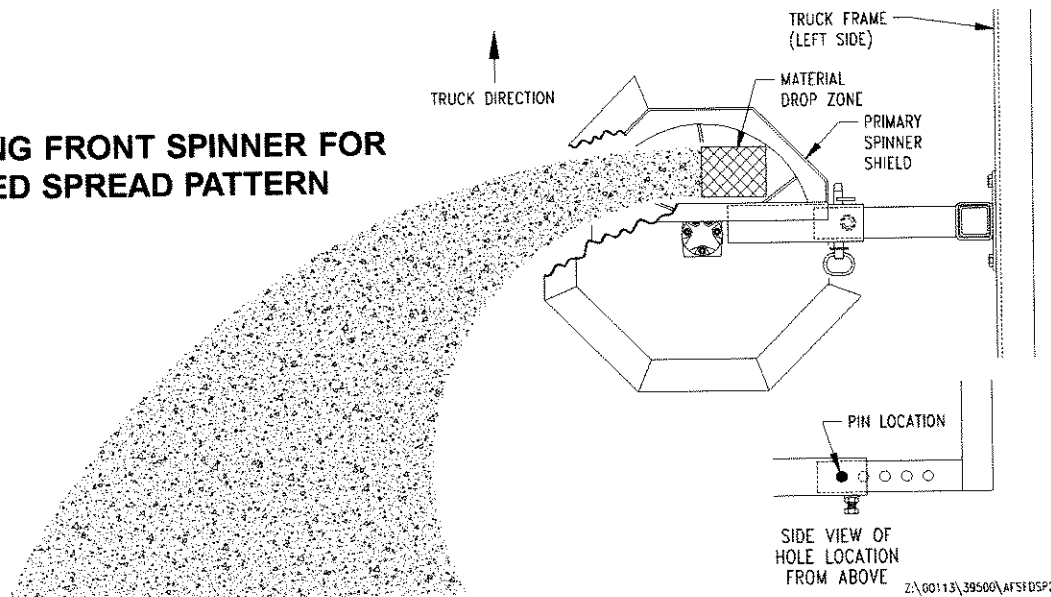

Bulk of material is spread to left side of truck when spinner is moved to outside hole (as shown) where material drop zone is over **right forward** area of spinner disk. (See following page for obtaining spread pattern to rear of truck.)

Spinner assembly can be adjusted to intermediate hole positions for spread patterns which are a combination of the extremes shown on this page and on the following page.

ADJUSTING FRONT SPINNER FOR DESIRED SPREAD PATTERN

(continued)

(See previous page for obtaining spread pattern to left side of truck)

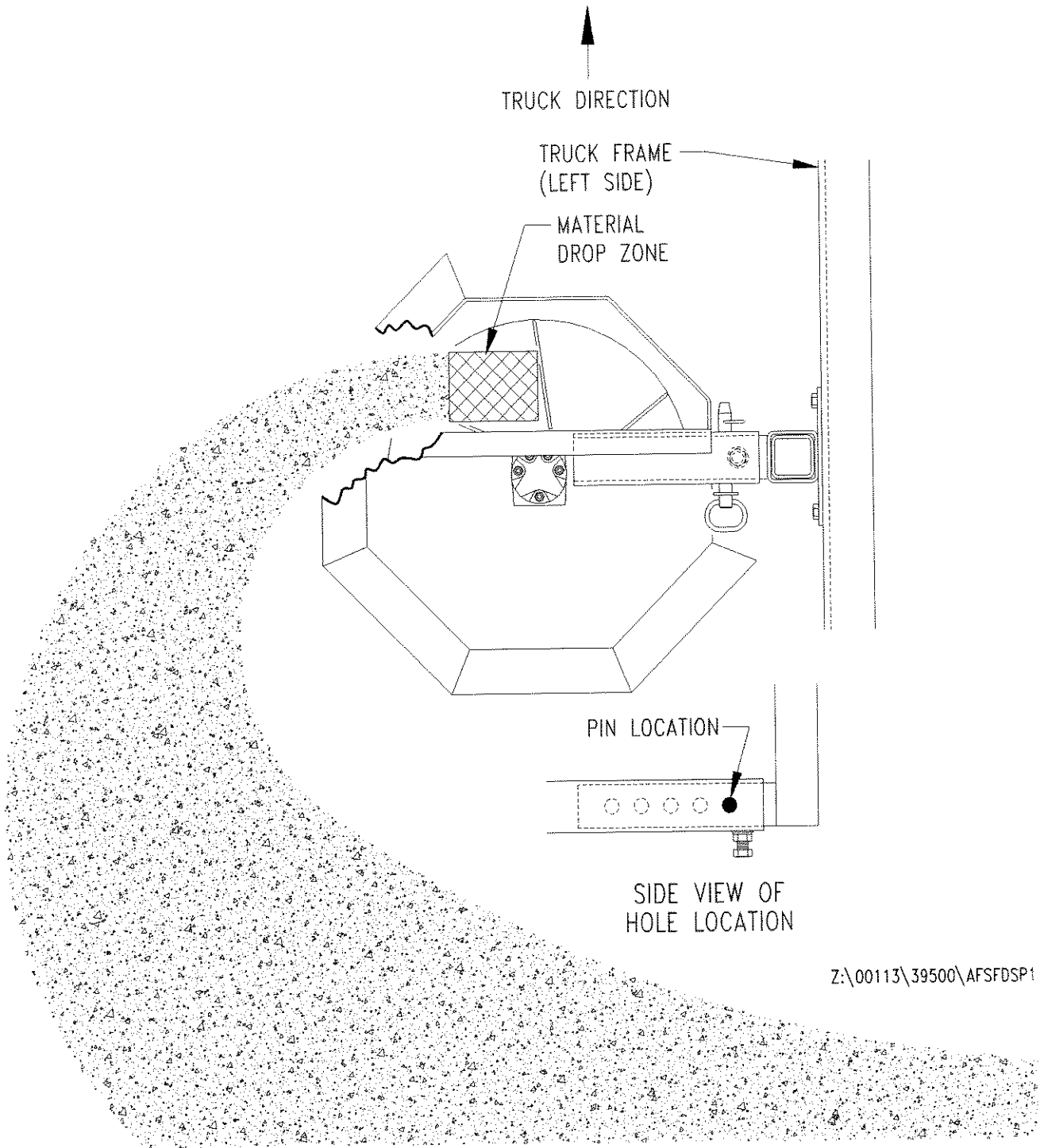

Z:\00113\39500\AFSFDSP1

Bulk of material is spread around to rear of truck when spinner is moved to inside hole (as shown) where material drop zone is over left forward area of spinner disk.

Spinner assembly can be adjusted to intermediate hole positions for spread patterns which are a combination of the extremes shown on this page and on the previous page.

ADJUSTING REAR SPINNER FOR DESIRED SPREAD PATTERN

(continued on next page)

(See following page for obtaining spread pattern around to rear of truck)

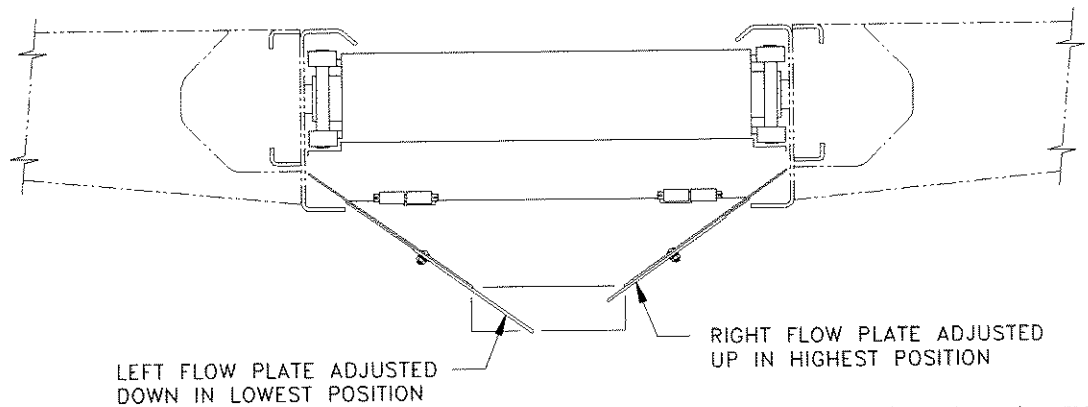
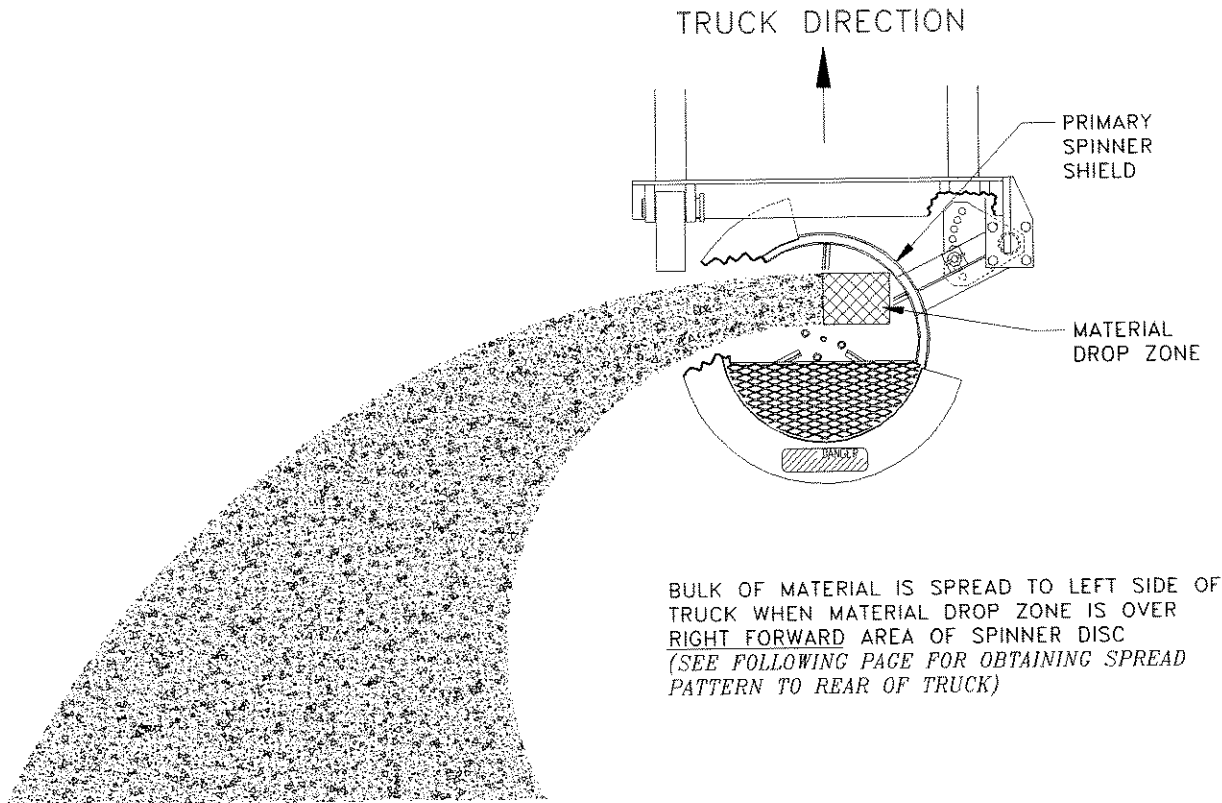

Noted position of flow plates will give approximate spread pattern shown above. Flow plates can be adjusted to intermediate positions for spread patterns which are a combination of the extremes shown on this page and on the following page.

IMPORTANT: After adjusting sliding plates for desired spread pattern, observe material falling through chute to be sure there is adequate opening for the amount of material being spread.

As a rule, if one plate is adjusted in a particular direction, then the other plate should be adjusted equally in the opposite direction.

ADJUSTING REAR SPINNER FOR DESIRED SPREAD PATTERN

(continued on next page)

(See following page for obtaining spread pattern around to rear of truck)

TRUCK DIRECTION

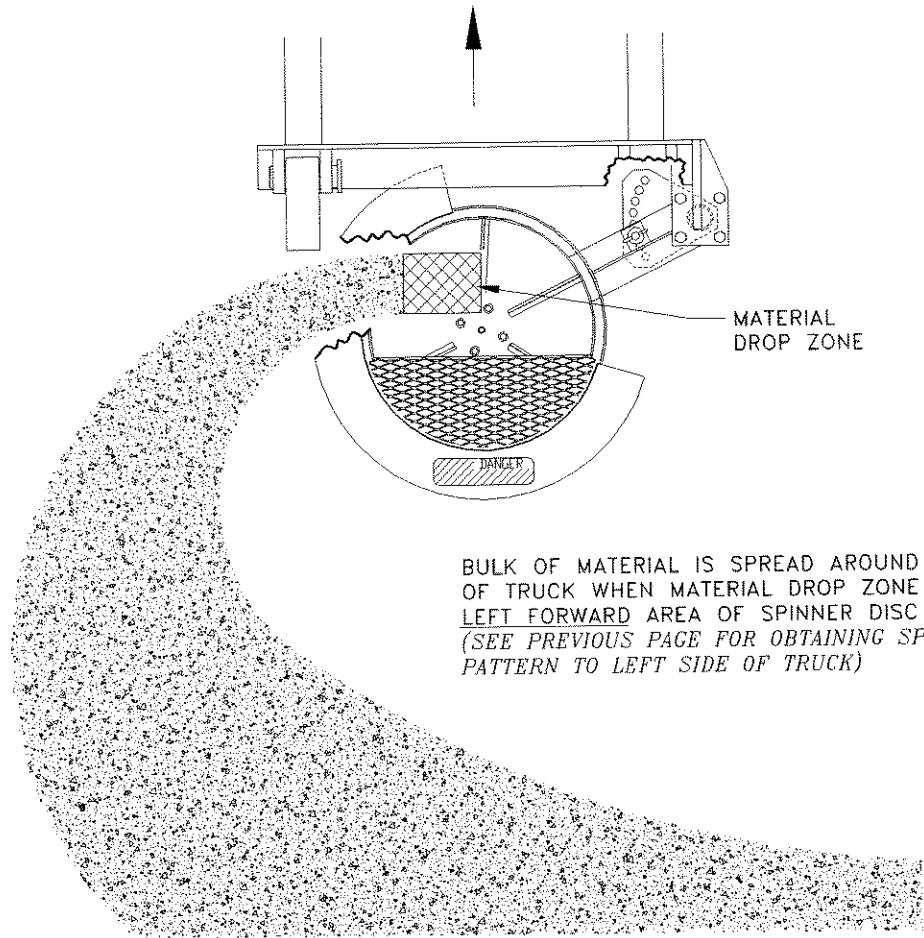

BULK OF MATERIAL IS SPREAD AROUND TO REAR OF TRUCK WHEN MATERIAL DROP ZONE IS OVER LEFT FORWARD AREA OF SPINNER DISC
(SEE PREVIOUS PAGE FOR OBTAINING SPREAD PATTERN TO LEFT SIDE OF TRUCK)

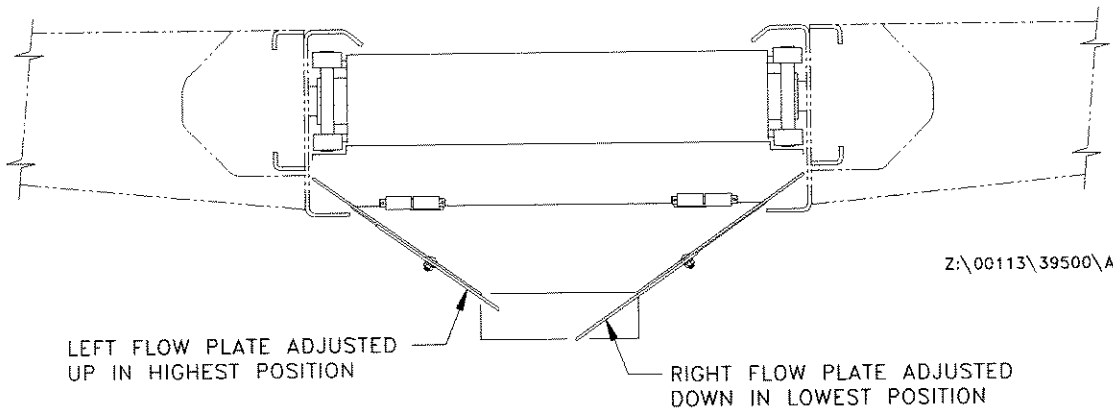

Z:\00113\39500\AR5FDSP2

Noted position of flow plates will give approximate spread pattern shown above. Flow plates can be adjusted to intermediate positions for spread patterns which are a combination of the extremes shown on this page and on the previous page.

IMPORTANT: After adjusting sliding plates for desired spread pattern, observe material falling through chute to be sure there is adequate opening for the amount of material being spread.

As a rule, if one plate is adjusted in a particular direction, then the other plate should be adjusted equally in the opposite direction.

PIVOTING REAR SPINNER IN POSITIONS OTHER THAN FOR SPREADING

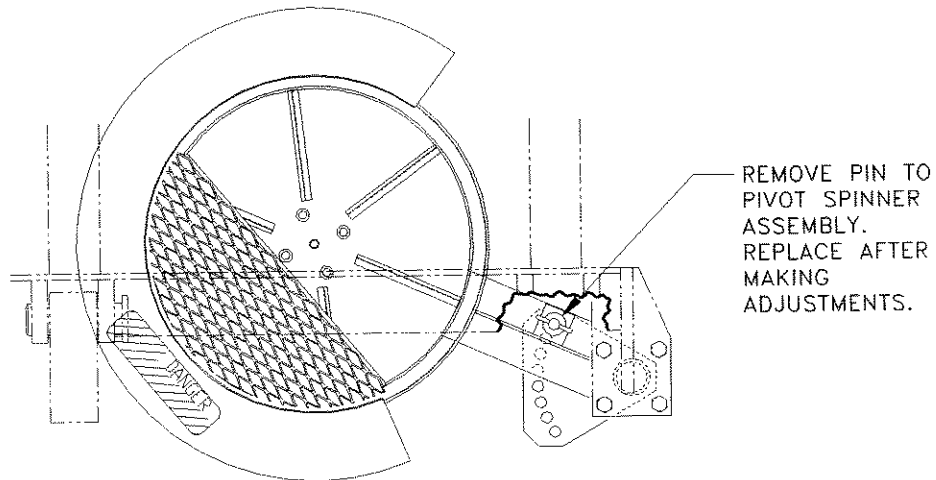

SPINNER SHOWN PIVOTED UNDER BODY WHEN NOT IN USE

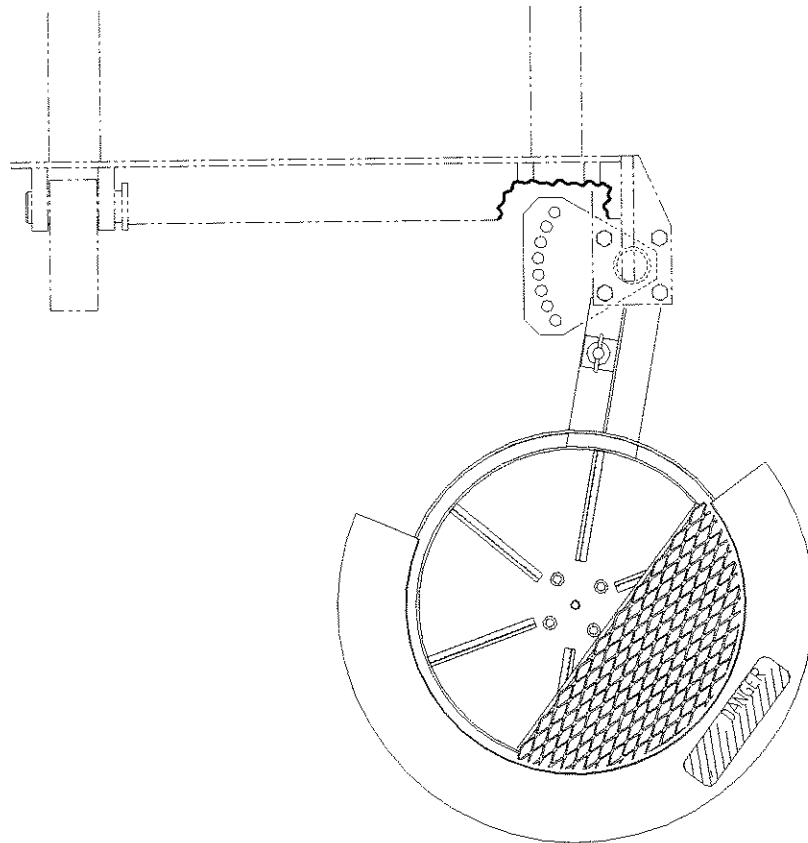

SPINNER SHOWN PIVOTED COMPLETELY OUT OF THE WAY FOR UNOBSTRUCTED DISCHARGING OF MATERIAL, AND FOR EASIER REMOVAL OF SPINNER ASSEMBLY.

Z:\00113\39500\PRS

RECOMMENDED REGULAR MAINTENANCE

DANGER!

BEFORE PERFORMING MAINTENANCE OPERATIONS. PARK VEHICLE ON LEVEL GROUND. SET PARKING BRAKE, SHUT OFF ALL POWER, AND MAKE SURE ALL MOVEMENT HAS STOPPED

If body is raised, it must be securely blocked so it cannot come down. Support blocks must not be removed until there is no danger of anyone being under body when body is lowered.

1. Periodic lubrication is required for proper operation. The following are components that require regular and/or seasonal inspection and lubrication. Refer to lubrication schedule chart for frequency.

For all points of lubrication, use good standard practice of wiping clean the engine area of lubricant entry before adding lubricant.

- a. Two rear and two front conveyor bearings, and one cross auger bearing (if furnished) require lubrication. (Caution should be observed to avoid overgreasing as damage may result to seals.)
- b. A grease fitting is provided on the latch handle pivot at left front corner of the body. Regular lubrication is required due to the loading and movement in this assembly.
- c. An oil hole is provided near the top of the feedgate jack. Use the heaviest weight oil possible that can be squirted out of an oil can. When oiling, push tip of oil can straight into hole as far as possible and squirt sharply so oil will be applied to screw. There is no danger of over oiling.
- d. A grease fitting is provided in each hinge block in rear body hinge assembly. Regular lubrication is required due to the loading and movement at these pivot points.
- e. A grease fitting is provided in each of the upper hoist cylinder mounting blocks and in each of the lower cylinder mounting blocks. Regular lubrication is required due to the loading and movement at these pivot points.

- f. A coating of grease on all adjusting and sliding parts is recommended for easier adjustment.

EXAMPLES:

- Drag chain take-up bolts
- Drag chain take-up slides
- Front Feedgate slides
- Rear feedgate adjusting parts

- g. Greasing universal joints in hydraulic pump drive line is recommended with each truck lubricating.

- h. If unit is going to be out of use for several days, oiling conveyor drag chain is recommended.

Body Lubrication Schedule Chart

FRONT AND REAR ----- EVERY 15 HRS.
CONVEYOR BEARINGS (GREASE)

CROSSAUGER CONVEYOR ----- EVERY 15 HRS.
BEARING (GREASE)

TAILGATE LATCH HANDLE ----- WEEKLY
PIVOT (GREASE)

FEEDGATE JACK (HEAVY OIL) ----- WEEKLY

BODY REAR HINGE (GREASE) ----- EVERY 3 MONTHS

CYLINDER TRUNNION PINS (GREASE) ----- EVERY 3 MONTHS
(UPPER AND LOWER)

2. **Check hydraulic oil level in reservoir.** It should be visible in sight level gauge mounted on side of reservoir. A reservoir requiring periodic refilling indicates a leak exists. Maintaining a full reservoir aids in cooler hydraulic operation. See page 6 for hydraulic oil type.

IMPORTANT: AVOID GETTING CONTAMINANTS IN RESERVOIR WHEN FILLING.

3. **Check for oil leaks** at all hose fitting connections, and tighten if necessary.
4. **Hydraulic oil filter cartridge** should be replaced if gauge pointer is in red zone when hydraulic system is operating.
5. **Clean quick disconnects** before taking apart or connecting.

RECOMMENDED REGULAR MAINTENANCE

(CONTINUED)

- 6. **Protect quick disconnects** after taking apart with well fitting caps and plugs, oily rag, or other suitable protection.
- 7. **Conveyor drag chain slack** should be taken up after initial start up, then checked periodically and taken up so distance between centerline of rear sprocket and point where chain contacts skid bar is 18 to 20 inches. (See illustration below.)

Note: If your unit is equipped with conveyor reversing capability, it will be necessary to check the slack condition more often so chain "bunching" does not occur at top-front of conveyor when conveyor is operated in rear direction.

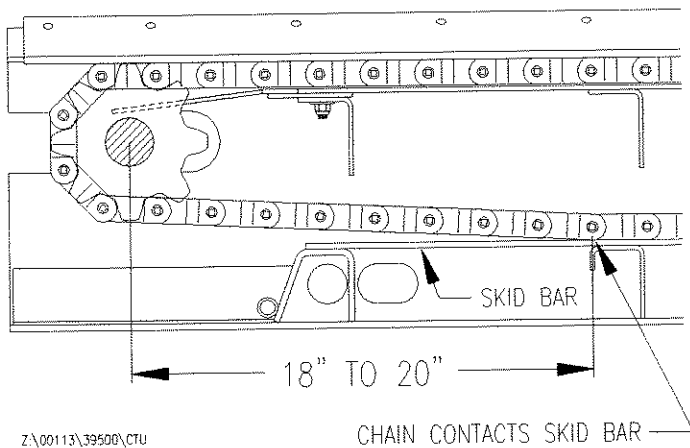

- 8. **Your spread pattern** is largely determined by the ease at which material slides off the spinner blades. Periodically inspect spinner and blades, and remove any material that may be sticking to them.
- 9. **Salt and other ice melting chemicals** are highly water-soluble materials and can be removed easily with plain water. Periodically hose off entire unit paying close attention to adjusting mechanisms and moving parts.
- 10. **During freezing weather** body should be kept empty to prevent material from freezing on drag chain.
- 11. **If hoist cylinder begins to close slowly while in use** due to combination dust-oil buildup on cylinder surfaces, hydraulic oil may be used to cleanse surfaces of each stage. Then apply a heavy coat of clean hydraulic oil, raise and lower cylinder two or three times and wipe off excess oil.

THE FOLLOWING PAGES INCLUDE EXPLODED VIEW DRAWINGS AND PARTS LISTS

Hoist and Body Mounting Group -----	33
Front Drive Conveyor Assembly -----	34
Front Gate Assembly & Closed Front Assembly -----	37
Rear Drive Conveyor Assembly -----	38
Mid Size Conveyor Assembly -----	42
High Conveyor Cover Assembly -----	43
Decal Group -----	44
Tailgate And Revolving Feedgate Assembly -----	46
Tailgate and Sliding Feedgate Assembly -----	48
Tailgate Latch Assembly (Full, Mid Size Manual & Air Operated) -----	50
Front Spinner Assembly -----	52
Rear Spinner Assembly -----	54
Front Cross Auger Assembly -----	56
Standard Parts Available For Hydraulic Motors -----	58
Lift In/Lift Out Top Screens -----	59

NOTE: SEE PAGE 62 FOR ORDERING PARTS.

HOIST AND BODY MOUNTING GROUP

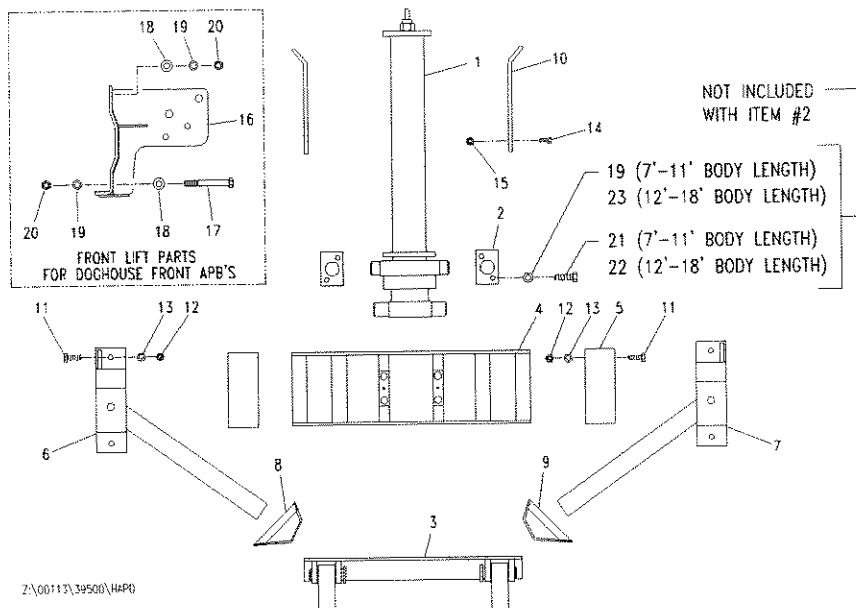

Item	Part Number	Qty.	Description
1	04107-023-09	1	Cylinder, Hydraulic Hoist (Double Acting - 7' Mid-Size)
	04107-023-06	1	Cylinder, Hydraulic Hoist (8' Body Length)
	04107-023-05	1	Cylinder, Hydraulic Hoist (9', 10' Body Length)
	04107-023-14	1	Cylinder, Hydraulic Hoist (Double Acting - 9' & 10' Body)
	04107-023-04	1	Cylinder, Hydraulic Hoist (12', 13' & 14' Body Length)
	04107-023-07	1	Cylinder, Hydraulic Hoist (Double Acting -12',13' & 14')
	04107-023-12	1	Cylinder, Hydraulic Hoist (18' Body Length)
	04107-023-16	1	Cylinder, Hydraulic Hoist (Single Acting 3 1/2"/80")
	04107-023-17	1	Cylinder, Hydraulic Hoist (Single Acting 3 1/2"/90")
	04107-023-20	1	Cylinder, Hydraulic Hoist (Double Acting 3 1/2"/90")
2	04107-024-03	2	Block, (7'- 11' Body Length)
	04107-024-06	2	Block, (12' - 18' Body Length)
3	04107-024-08	1	Assembly, Back Hinge (7' Mid-Size)
	04107-024-04	1	Assembly, Back Hinge (All Body Lengths except 7')
4	00112-494-04	1	Weldment, Lift Frame (7' Mid Size)
	00112-494-01	1	Weldment, Lift Frame (8' - 11' Body Length)
	00112-494-03	1	Weldment, Lift Frame (12' - 18' Body Length)
5	00112-492-03	2	Angle, Frame Mounting (7' Mid Size)
	00112-492-01	2	Angle, Frame Mounting (8' - 11' Body Length)
	00112-492-02	2	Angle, Frame Mounting (12' - 18' Body Length)
6	00112-510-01	1	Weldment, Left Prop
7	00112-510-02	1	Weldment, Right Prop
8	00112-857-01	1	Weldment, Left Prop Seat
9	00112-857-02	1	Weldment, Right Prop Seat
10	00112-493-02	2	Guide, Body (7' Mid Size)
	00112-493-01	2	Guide, Body (All Body Lengths except 7')
11	04003-006-19	6	Bolt, 5/8"-18 x 2" H.H. Gr. 8
12	04003-801-31	6	Nut, 5/8"-18 Hex Gr. 8
13	04004-001-10	6	Lockwasher, 5/8"
14	04003-005-07	4	Bolt, 1/2"-13 x 2" H.H. Gr. 5
15	04003-806-03	4	Nut, 1/2"-13 Serrated Flange
16	00114-858-01	1	Weldment, Lift Bracket (8' - 11' Body Length)
	00114-858-02	1	Weldment, Lift Bracket (12' - 18' Body Length)
17	04003-007-18	4	Bolt, 3/4"-10 x 6" H.H. Gr. 5
18	04004-002-50	6	Washer, Heavy, 25/32" I.D. (Special)
19	04004-001-11	10	Lockwasher, 3/4"
20	04003-807-13	6	Locknut, 3/4"-10 Center Lock
21	04003-007-17	4	Bolt, 3/4"-16 NF X 2-1/2" H.H. Gr. 8
22	04003-009-05	4	Bolt, 1"-14 NF X 2-1/2" H>H> Gr. 8
23	04004-001-13	4	Lockwasher, 1"

FRONT DRIVE CONVEYOR ASSEMBLY

(Single and Dual Motor Drives)

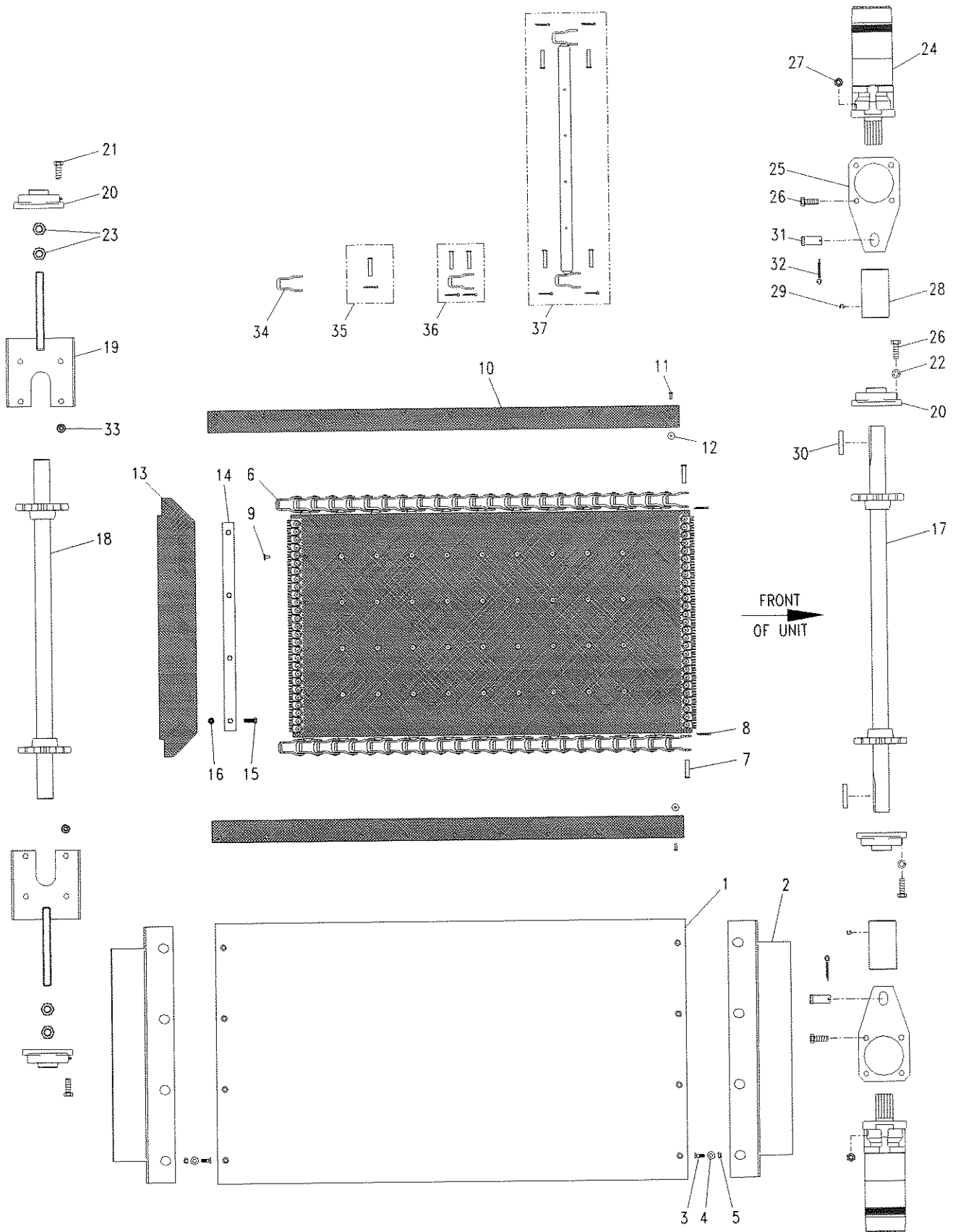

FRONT DRIVE CONVEYOR ASSEMBLY

(Single and Dual Motor Drives)

<u>Item</u>	<u>Part Number</u>	<u>Qty.</u>	<u>Description</u>	
1	00112-402-49	1	Floor, Conveyor - 8 ft. (1/4" Carbon Steel Plate)	
	00112-402-53	1	Floor, Conveyor - 9 ft. (1/4" Carbon Steel Plate)	
	00112-402-57	1	Floor, Conveyor - 10 ft. (1/4" Carbon Steel Plate)	
	00112-402-61	1	Floor, Conveyor - 11 ft. (1/4" Carbon Steel Plate)	
	00112-402-65	1	Floor, Conveyor - 12 ft. (1/4" Carbon Steel Plate)	
	00112-402-69	1	Floor, Conveyor - 13 ft. (1/4" Carbon Steel Plate)	
	00112-402-73	1	Floor, Conveyor - 14 ft. (1/4" Carbon Steel Plate)	
	00112-402-77	1	Floor, Conveyor - 15 ft. (1/4" Carbon Steel Plate)	
	00112-402-81	1	Floor, Conveyor - 16 ft. (1/4" Carbon Steel Plate)	
	00112-402-85	1	Floor, Conveyor - 17 ft. (1/4" Carbon Steel Plate)	
	00112-402-93	1	Floor, Conveyor - 18 ft. (1/4" Carbon Steel Plate)	
	2	00112-501-02	2	Weldment, Nosepiece (Only for 1/4" Plate Conveyor Floors)
	3	04003-018-04	8	Screw, 3/8"-16 x 1 1/4" Flat Head
4	04004-002-08	8	Flatwasher, 3/8"	
5	04003-804-02	8	Locknut, 3/8"-16 Hex	
6	04045-290-08	1	Assembly, Belt Over Chain - 8 ft.	
	04045-290-09	1	Assembly, Belt Over Chain - 9 ft.	
	04045-290-10	1	Assembly, Belt Over Chain - 10 ft.	
	04045-290-11	1	Assembly, Belt Over Chain - 11 ft.	
	04045-290-12	1	Assembly, Belt Over Chain - 12 ft.	
	04045-290-13	1	Assembly, Belt Over Chain - 13 ft.	
	04045-290-14	1	Assembly, Belt Over Chain - 14 ft.	
	04045-290-15	1	Assembly, Belt Over Chain - 15 ft.	
	04045-290-16	1	Assembly, Belt Over Chain - 16 ft.	
	04045-290-17	1	Assembly, Belt Over Chain - 17 ft.	
04045-290-18	1	Assembly, Belt Over Chain - 18 ft.		
7	See Item #35	2	Pin, Connector (7/16" Dia. For Drives "K" Chain)	
	See Item #35	2	Pin, Connector (15/32" Dia. For Allied-Locke "XH" Chain)	
8	See Item #35	2	Pin, Cotter (1/8" x 3/4" For Drives "K" Chain)	
	See Item #35	2	Pin, Cotter (3/16" x 1" For Allied-Locke "XH" Chain)	
9	04002-039-00	A/N	Rivet, 1/4" x .750 Blind (Used to secure belt to chain bars)	
10	04076-073-08	2	Strip, Seal - 8 ft.	
	04076-073-09	2	Strip, Seal - 9 ft.	
	04076-073-10	2	Strip, Seal - 10 ft.	
	04076-073-11	2	Strip, Seal - 11 ft.	
	04076-073-12	2	Strip, Seal - 12 ft.	
	04076-073-13	2	Strip, Seal - 13 ft.	
	04076-073-14	2	Strip, Seal - 14 ft.	
	04076-073-15	2	Strip, Seal - 15 ft.	
	04076-073-16	2	Strip, Seal - 16 ft.	
	04076-073-17	2	Strip, Seal - 17 ft.	
04076-073-18	2	Strip, Seal - 18 ft.		
11	04002-036-00	A/N	Rivet, 1/4" x .865 Blind	
12	04004-002-38	A/N	Washer, Backup (Special)	
13	04076-070-00	1	Wiper, Crossangle	
14	00112-540-01	1	Bar, Wiper Backup	
15	04003-003-04	4	Bolt, 3/8"-16 x 1 1/4" H.H. Gr. 5	
16	04003-806-02	4	Nut, 3/8"-16 Serrated Flange	
17	00112-538-01	1	Weldment, Drive Shaft	
18	00112-539-01	1	Weldment, Idler Shaft	
19	00112-524-01	2	Weldment, Take-up Plate	
20	04080-059-00	4	Bearing, 2"	
21	04003-006-02	8	Bolt, 5/8"-11 x 2" H.H. Gr. 5	

FRONT DRIVE CONVEYOR ASSEMBLY

(Single and Dual Motor Drives) Continued from Page 35

<u>Item</u>	<u>Part Number</u>	<u>Qty</u>	<u>Description</u>
22	04004-001-10	8	Lockwasher, 5/8" Split
23	04003-801-14	4	Nut, 1"-8 Hex Plain
24	04101-136-00	1/2*	Motor, Hydraulic
	04101-143-00	1	Motor, Hydraulic (w/Electric Speed Sensor)
25	00112-384-01	1/2*	Arm. Torque
26	04003-006-14	12/16*	Bolt, 5/8"-11 x 2 1/4" H.H. Gr. 5
27	04003-807-12	4/8*	Locknut, 5/8"-11 Center Lock
28	00112-807-00	1/2*	Weldment, Coupling
29	04007-012-07	1/2*	Setscrew, 1/2"-20 x 1/2" Allen Head
30	04031-005-00	1/2*	Key, 1/2" x 3" Square
31	04014-006-03	1/2*	Pin, 1" x 2 1/4" Clevis
32	04010-005-01	1/2*	Pin, 3/16" X 1 1/2" Cotter
33	04003-806-04	8	Nut, 5/8"-11 Serrated Flange
34	04045-321-00	2	Link, Connector (7/16" Dia. Hole w/Teardrop) (Drives "K" Chain)
	04045-321-01	2	Link, Connector (15/32" Dia. Hole w/Teardrop) (Allied-Locke "XH" Chain)
35	04045-160-00	2	Connector, Pin w/Cotter (7/16" Dia. w/Teardrop) (Drives "K" Chain)
	04045-160-01	2	Connector, Pin w/Cotter (15/32" Dia. w/Teardrop) (Allied-Locke "XH" Chain)
36	04045-179-00	2	Connector Link, w/Pins & Cotters (7/16" Dia. Pins) (Drives "K" Chain)
	04045-179-01	2	Connector Link, w/Pins & Cotters (15/32" Dia. Pins) (Allied-Locke "XH" Chain)
37	04045-320-00	1	Bar Weldment, w/Holes, w/4 Pins & Cotters (7/16" Pin Dia.) (Drives "K" Chain)
	04045-320-01	1	Bar Weldment, w/Holes, w/4 Pins & Cotters (15/32" Pin Dia.) (Allied-Locke "XH" Chain)

A/N - As needed depending upon length of your unit (Specify quantity when ordering)

***X/X - First number is qty. for single motor drive units, second number is qty for dual motor drive units.**

NOTE: Part numbers shown are for standard carbon steel units, for materials other than carbon steel contact your dealer.

FRONT GATE ASSEMBLY & CLOSED FRONT ASSEMBLY

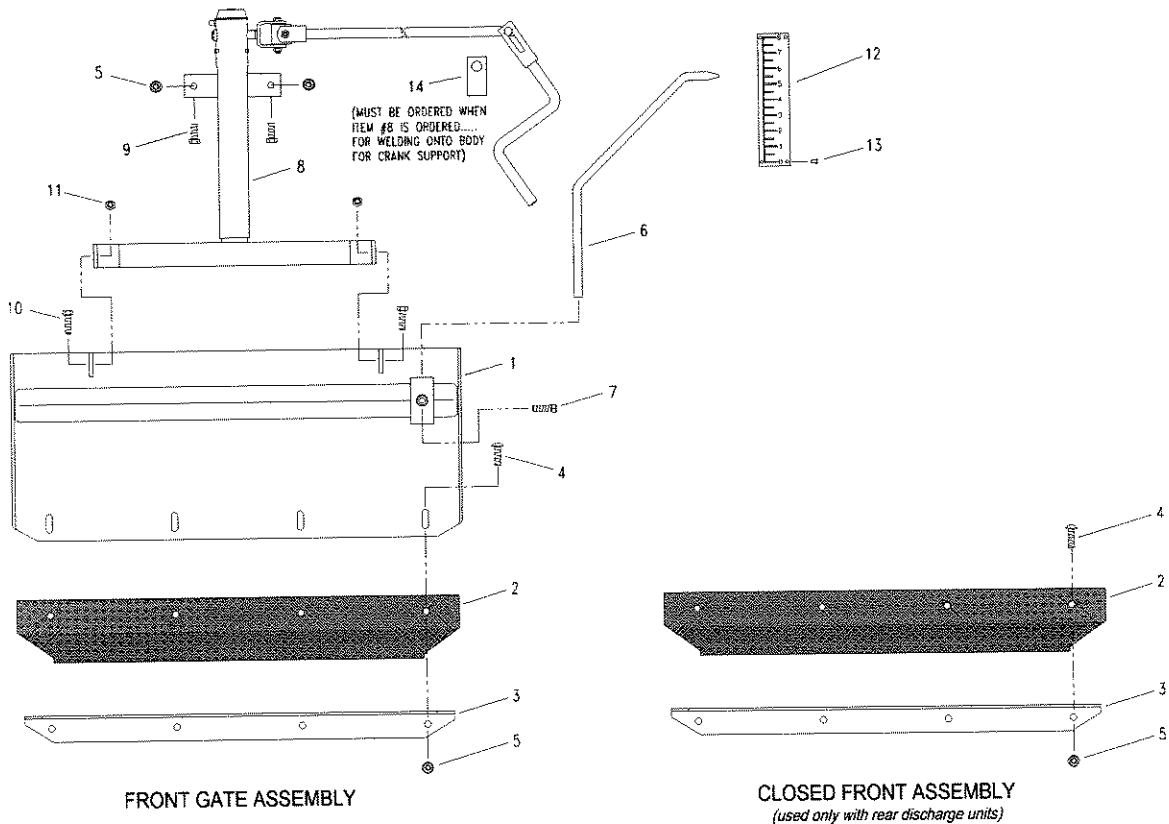

Z:\00113\39500\FGA

<u>Item</u>	<u>Part Number</u>	<u>Qty.</u>	<u>Description</u>
1	00112-497-01	1	Weldment, Front Gate
2	04076-071-00	1	Wiper, Feedgate
3	00112-395-01	1	Angle, Gate Backup
4	04003-033-04	4	Bolt, 3/8"-16 X 1 1/4" Carriage Gr. 5
5	04003-806-02	6/4*	Nut, 3/8"-16 Serrated Flange
6	00112-439-01	1	Pointer
7	04006-009-02	1	Setscrew, 3/8" X 1 1/4" Square Head
8	00112-531-01	1	Assembly, Gate Jack
9	04003-003-03	2	Bolt, 3/8"-16 X 1" H.H. Gr. 5
10	04003-003-04	2	Bolt, 3/8"-16 X 1 1/4" H.H. Gr. 5
11	04003-804-02	2	Locknut, 3/8"-16 Nylon Insert
12	04621-004-00	1	Ruler, 8" Gate
13	04002-037-00	4	Rivet, 3/16" X .315 Pop
14	00112-359-01	1	Bar, Crank Support

Note: Part numbers shown are for standard carbon steel units, for materials other than carbon steel contact your dealer.

*X/X First number is quantity for front gate assembly,
Second number is quantity for closed front assembly.

REAR DRIVE CONVEYOR ASSEMBLY

(Single and Dual Motor Drives)

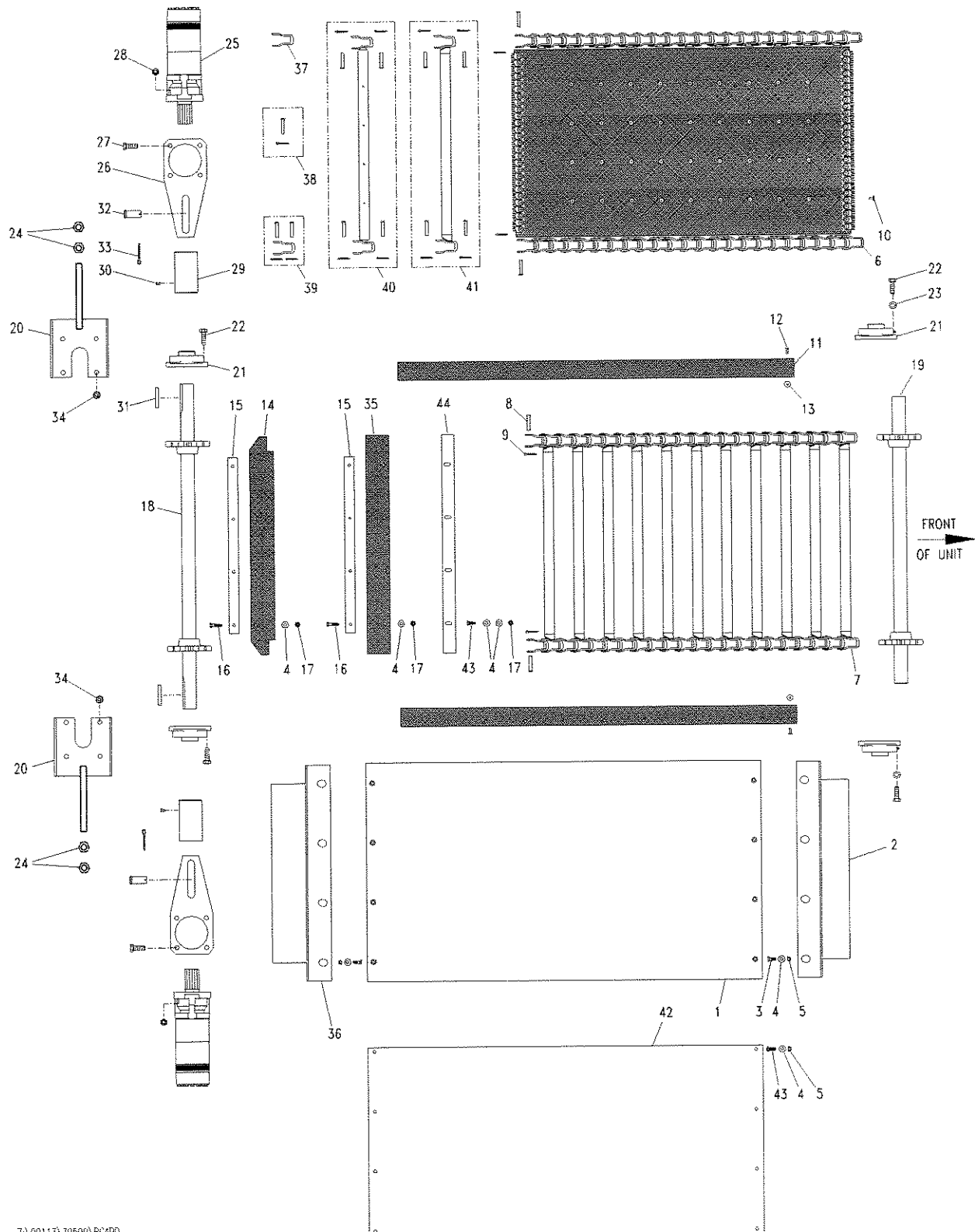

Z:\00113\39500\RCAPD

REAR DRIVE CONVEYOR ASSEMBLY

(Single and Dual Motor Drives)

<u>Item</u>	<u>Part Number</u>	<u>Qty.</u>	<u>Description</u>	
1	00112-402-49	1	Floor, Conveyor - 8 ft. (1/4" Carbon Steel Plate)	
	00112-402-53	1	Floor, Conveyor - 9 ft. (1/4" Carbon Steel Plate)	
	00112-402-57	1	Floor, Conveyor - 10 ft. (1/4" Carbon Steel Plate)	
	00112-402-61	1	Floor, Conveyor - 11 ft. (1/4" Carbon Steel Plate)	
	00112-402-65	1	Floor, Conveyor - 12 ft. (1/4" Carbon Steel Plate)	
	00112-402-69	1	Floor, Conveyor - 13 ft. (1/4" Carbon Steel Plate)	
	00112-402-73	1	Floor, Conveyor - 14 ft. (1/4" Carbon Steel Plate)	
	00112-402-77	1	Floor, Conveyor - 15 ft. (1/4" Carbon Steel Plate)	
	00112-402-81	1	Floor, Conveyor - 16 ft. (1/4" Carbon Steel Plate)	
	00112-402-85	1	Floor, Conveyor - 17 ft. (1/4" Carbon Steel Plate)	
	00112-402-93	1	Floor, Conveyor - 18 ft. (1/4" Carbon Steel Plate)	
	2	00112-501-02	**	Weldment, Nosepiece (Only for 1/4" Plate Conveyor Floors)
	3	04003-018-04	8	Screw, 3/8"-16 x 1 1/4" Flat Head
4	04004-002-08	32	Flatwasher, 3/8"	
5	04003-804-02	16	Locknut, 3/8"-16 Hex	
6	04045-290-08	1	Assembly, Belt Over Chain - 8 ft.	
	04045-290-09	1	Assembly, Belt Over Chain - 9 ft.	
	04045-290-10	1	Assembly, Belt Over Chain - 10 ft.	
	04045-290-11	1	Assembly, Belt Over Chain - 11 ft.	
	04045-290-12	1	Assembly, Belt Over Chain - 12 ft.	
	04045-290-13	1	Assembly, Belt Over Chain - 13 ft.	
	04045-290-14	1	Assembly, Belt Over Chain - 14 ft.	
	04045-290-15	1	Assembly, Belt Over Chain - 15 ft.	
	04045-290-16	1	Assembly, Belt Over Chain - 16 ft.	
	04045-290-17	1	Assembly, Belt Over Chain - 17 ft.	
7	04045-290-18	1	Assembly, Belt Over Chain - 18 ft.	
	04045-121-08	1	Weldment, Drag Chain - 8 ft.	
	04045-121-09	1	Weldment, Drag Chain - 9 ft.	
	04045-121-10	1	Weldment, Drag Chain - 10 ft.	
	04045-121-11	1	Weldment, Drag Chain - 11 ft.	
	04045-121-12	1	Weldment, Drag Chain - 12 ft.	
	04045-121-13	1	Weldment, Drag Chain - 13 ft.	
	04045-121-14	1	Weldment, Drag Chain - 14 ft.	
	04045-121-15	1	Weldment, Drag Chain - 15 ft.	
	04045-121-16	1	Weldment, Drag Chain - 16 ft.	
8	04045-121-17	1	Weldment, Drag Chain - 17 ft.	
	04045-121-18	1	Weldment, Drag Chain - 18 ft.	
9	See Item #38	2	Pin, Connector (7/16" Dia. For Drives "K" Chain)	
	See Item #38	2	Pin, Connector (15/32" Dia. For Allied-Locke "XH" Chain)	
10	See Item #38	2	Pin, Cotter (1/8" x 3/4" for Drives "K" Chain)	
	See Item #38	2	Pin, Cotter (3/16" x 1" For Allied-Locke "XH" Chain)	
11	04002-039-00	A/N	Rivet, 1/4" x .750 Blind (Used to secure Belt to Chain Bars)	
11	04076-073-28	2	Strip, Seal - 8 ft.	
	04076-073-29	2	Strip, Seal - 9 ft.	
	04076-073-30	2	Strip, Seal - 10 ft.	
	04076-073-31	2	Strip, Seal - 11 ft.	
	04076-073-32	2	Strip, Seal - 12 ft.	
	04076-073-33	2	Strip, Seal - 13 ft.	
	04076-073-34	2	Strip, Seal - 14 ft.	
	04076-073-35	2	Strip, Seal - 15 ft.	
	04076-073-36	2	Strip, Seal - 16 ft.	
	04076-073-37	2	Strip, Seal - 17 ft.	
	04076-073-38	2	Strip, Seal - 18 ft.	

** Qty. is (1) at front only if drag chain (without belt) is used;
Qty. is (2) if belt over chain is used (See Item #36).

REAR DRIVE CONVEYOR ASSEMBLY

(Single and Dual Motor Drives) Continued from page 39

<u>Item</u>	<u>Part Number</u>	<u>Qty.</u>	<u>Description</u>
12	04002-036-00	A/N	Rivet, Blind 1/4" x .865 (Secures conveyor seal strips)
13	04004-002-38	A/N	Washer, Backup (Special)
14	04076-107-00	1	Wiper, Lower Rear
15	00112-540-01	2	Bar, Wiper Backup
16	04003-003-05	8	Bolt, 3/8"-16 x 1 1/2" H.H. Gr. 5
17	04003-806-02	12	Nut, 3/8"-16 Serrated Flange
18	00112-538-01	1	Weldment, Drive Shaft
19	00112-539-01	1	Weldment, Idler Shaft
20	00112-524-01	2	Weldment, Take-up Plate
21	04080-059-00	4	Bearing, 2"
22	04003-006-02	16	Bolt, 5/8"-11 x 2" H.H. Gr. 5
23	04004-001-10	8	Lockwasher, 5/8" Split
24	04003-801-14	4	Nut, 1"-8 Hex Plain
25	04101-136-00	1/2 *	Motor, Hydraulic
	04101-143-00	1	Motor, Hydraulic (w/Electronic Speed Sensor)
26	00112-384-02	1/2 *	Arm, Torque
27	04003-006-14	4/8 *	Bolt, 5/8"-11 x 2 1/4" H.H. Gr. 5
28	04003-807-12	4/8 *	Locknut, 5/8"-11 Center Lock
29	00112-807-00	1/2 *	Weldment, Coupling
30	04007-012-07	1/2 *	Setscrew, 1/2"-20 x 1/2" Allen Head
31	04031-005-00	1/2 *	Key, 1/2" x 3" Square
32	04014-006-03	1/2 *	Pin, 1" x 2 1/4" Clevis
33	04010-005-01	1/2 *	Pin, 3/16" x 1 1/2" Cotter
34	04003-806-04	8	Nut, 5/8"-11 Serrated Flange
35	04076-086-00	1	Wiper, Inside Crossangle
36	00112-501-03	1 ***	Weldment, Nosepiece (Only for 1/4" Plate Conveyor Flrs.)
37	04045-321-00	1	Link, Connector (7/16" Dia. Hole w/Teardrop) (Drives "K" Chain)
	04045-321-01	1	Link, Connector (15/32" Dia. Hole w/Teardrop) (Allied-Locke "XH" Chain)
38	04045-160-00	2	Connector Pin, w/Cotter (7/16" Dia. w/Teardrop) (Drives "K" Chain)
	04045-160-01	2	Connector Pin, w/Cotter (15/32" Dia. w/Teardrop) (Allied-Locke "XH" Chain)
39	04045-179-00	2	Connector Link, w/Pins & Cotters (7/16" Dia. Pins) (Drives "K" Chain)
	04045-179-01	2	Connector Link, w/Pins & Cotters (15/32" Dia, Pins) (Allied-Locke "XH" Chain)
40	04045-320-00	1	Bar Weldment, w/Holes, w/4 Pins & Cotters (7/16" Pin Dia.) (Drives "K" Chain)
	04045-320-01	1	Bar Weldment, w/Holes, w/4 Pins & Cotters (15/32" Pin Dia.) (Allied-Locke "XH" Chain)
41	04045-181-00	1	Bar Weldment, Plain w/4 Pins & Cotters (7/16" Pin Dia.) (Drives "K" Chain)
	04045-181-01	1	Bar Weldment, Plain w 4 Pins & Cotters (15/32" Pin Dia.) (Allied-Locke "XH" Chain)

REAR DRIVE CONVEYOR ASSEMBLY

(Single and Dual Motor Drives) Continued from page 40

<u>Item</u>	<u>Part Number</u>	<u>Qty.</u>	<u>Description</u>
****42	00115-671-01	1	Plate, Catch - 8 ft.
	00115-671-05	1	Plate, Catch - 9 ft.
	00115-671-09	1	Plate, Catch - 10 ft.
	00115-671-13	1	Plate, Catch - 11 ft.
	00115-671-17	1	Plate, Catch - 12 ft.
	00115-671-21	1	Plate, Catch - 13 ft.
	00115-671-25	1	Plate, Catch - 14 ft.
	00115-671-29	1	Plate, Catch - 15 ft.
	00115-671-33	1	Plate, Catch - 16 ft.
	00115-671-37	1	Plate, Catch - 17 ft.
	00115-671-45	1	Plate, Catch - 18 ft.
****43	04003-003-03	8	Bolt, 3/8"-16 x 1" H.H. Gr. 5
44	00115-669-01	1	Support, Wiper Bolting

A/N - As needed depending upon length of your unit (Specify quantity when ordering)

***X/X - First number is qty. for single motor drive units, second number is qty for dual motor drive units.**

***** - Qty. required at rear only if drag chain (without belt) is used**

****** - Used only on units with plain drag chain; not required on units with belt over chain.**

NOTE: Part numbers shown are for standard carbon steel units, for materials other than carbon steel contact your dealer.

PARTS LIST ONLY FOR MID SIZE CONVEYOR ASSEMBLIES

(For Front and Rear Drive with Belt Over Chain and Straight Chain)

<u>Item</u>	<u>Part Number</u>	<u>Qty.</u>	<u>Description</u>
1	00112-402-41	1	Floor, Conveyor - 7 ft. (7 Ga. Carbon Steel)
	00112-402-01	1	Floor, Conveyor - 8 ft. (7 Ga. Carbon Steel)
	00112-402-05	1	Floor, Conveyor - 9 ft.(7 Ga. Carbon Steel)
	00112-402-09	1	Floor, Conveyor - 10 ft. (7 Ga. Carbon Steel)
	00112-402-13	1	Floor, Conveyor - 11 ft. (7 Ga. Carbon Steel)
2	00112-501-01	1/2*	Weld, Nosepiece, 7 Ga.
	00112-501-04	1	Weldment, Nosepiece, 7 Ga. (Rear Drive Only)
3	04045-323-01	1	Weldment, Drag Chain, 7' - Rear Drive
	04045-323-02	1	Weldment, Drag Chain 8' - Rear Drive
	04045-323-03	1	Weldment, Drag Chain 9' - Rear Drive
	04045-323-04	1	Weldment, Drag Chain 10' - Rear Drive
	04045-323-05	1	Weldment, Drag Chain 11' - Rear Drive
4	04045-044-00	2	Pin, Drag Chain Connector
5	04045-048-00	2	Pin Cotter (For Drag Chain Connector Pin)
6	04076-073-27	2	Strip, Seal - 7 ft. - Rear Drive
	04076-073-28	2	Strip, Seal - 8 ft. - Rear Drive
	04076-073-29	2	Strip, Seal - 9 ft. - Rear Drive
	04076-073-30	2	Strip, Seal - 10 ft. - Rear Drive
	04076-073-31	2	Strip, Seal - 11 ft. - Rear Drive
	04076-073-07	2	Strip, Seal - 7 ft. - Front Drive
	04076-073-08	2	Strip, Seal - 8 ft. - Front Drive
	04076-073-09	2	Strip, Seal - 9 ft. - Front Drive
	04076-073-10	2	Strip, Seal - 10 ft. - Front Drive
	04076-073-11	2	Strip Seal - 11 ft. - Front Drive
	7	04002-036-00	A/N
04002-039-00		A/N	Rivet, 1/4" x .750 Blind(Secures Belt to Convey. Chain)
8	04004-002-38	A/N	Flatwasher, 1/4" Special
9	04076-070-00	1	Wiper, Crossangle Rubber
10	00112-540-01	2	Bar, Wiper Backup, 1/4"
11	00114-193-01	1	Weldment, Drive Shaft
12	00112-539-02	1	Weldment, Idler Shaft
13	00112-524-03	2	Weldment, Take-up Plate
14	04080-004-00	3	Bearing, 1 1/2" (2 - Bolt Flange)
15	04003-801-33	4	Nut, 1"-8 Hex, Gr 8 ZP
16	04101-094-00	1	Motor, Hydraulic (w/o Case Drain)(Rear Drive)
	04101-118-00	1	Motor, Hydraulic (w/Case Drain)(Front Drive)
17	00114-194-01	2/0*	Bar, Spacer (Between Motor Adapter & Take-up Plate)
13	00114-197-01	1	Weldment, Motor Adapter
19	04004-002-47	4	Flatwasher, 17/32 (At Motor Mounting Flange)
20	00107-080-00	4	Bushing, Motor (At Motor Mounting Flange)
21	04076-086-00	1	Wiper, Inside Crossangle Rubber (At Rear)
22	00115-671-41	1	Plate, Catch - 7 ft. - Rear Drive Only
	00115-671-01	1	Plate, Catch - 8 ft. - Rear Drive Only
	00115-671-05	1	Plate, Catch - 9 ft. - Rear Drive Only
	00115-671-09	1	Plate, Catch - 10 ft. - Rear Drive Only
	00115-671-13	1	Plate, Catch - 11 ft. - Rear Drive Only
			(Item #22 Is Installed Under Conveyor Chain)
23	04045-326-01	1	Assembly, Belt Over Chain - 7 ft. - Front Drive
	04045-326-02	1	Assembly, Belt Over Chain - 8 ft. - Front Drive
	04045-326-03	1	Assembly, Belt Over Chain - 9 ft. - Front Drive
	04045-326-04	1	Assembly, Belt Over Chain - 10 ft. - Front Drive

* X/X - First Qty. Is For Rear Drive/Second Qty. Is Front Drive.

A/N As needed depending upon length of your unit. (Specify quantity when ordering.)

NOTE: Standard hardware items not listed. All readily available locally.

HIGH CONVEYOR COVER ASSEMBLY

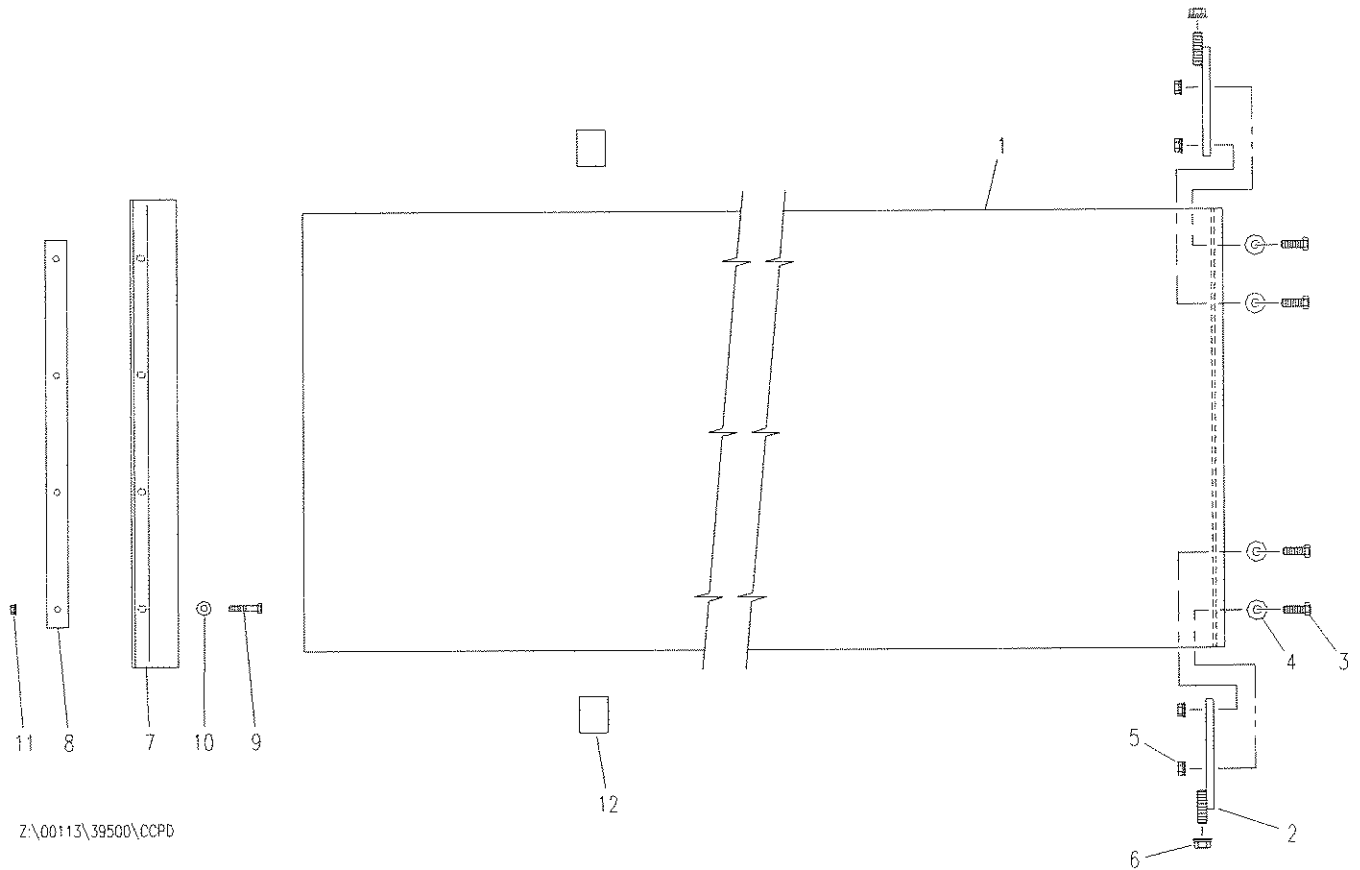

Z:\00113\39500\CCPD

<u>Item</u>	<u>Part Number</u>	<u>Qty.</u>	<u>Description</u>
1	00113-781-07	1	Weldment, Conveyor Cover - 7 ft. (7Ga. Carbon Steel)
	00113-781-08	1	Weldment, Conveyor Cover - 8 ft. (1/4" Carbon Steel)
	00113-781-09	1	Weldment, Conveyor Cover - 9 ft. (1/4" Carbon Steel)
	00113-781-10	1	Weldment, Conveyor Cover - 10 ft. (1/4" Carbon Steel)
	00113-781-11	1	Weldment, Conveyor Cover - 11 ft. (1/4" Carbon Steel)
	00113-781-12	1	Weldment, Conveyor Cover - 12 ft. (1/4" Carbon Steel)
	00113-781-13	1	Weldment, Conveyor Cover - 13 ft. (1/4" Carbon Steel)
	00113-781-14	1	Weldment, Conveyor Cover - 14 ft. (1/4" Carbon Steel)
	00113-781-15	1	Weldment, Conveyor Cover - 15 ft. (1/4" Carbon Steel)
	00113-781-16	1	Weldment, Conveyor Cover - 16 ft. (1/4" Carbon Steel)
	00113-781-17	1	Weldment, Conveyor Cover - 17 ft. (1/4" Carbon Steel)
	00113-781-54	1	Weldment, Conveyor Cover - 18 ft. (1/4" Carbon Steel)
2	00113-784-01	2	Weldment, Bolting Bar
3	04003-005-05	4	Bolt, 1/2"-13 x 1 1/2" H.H. Gr. 5
4	04004-002-10	4	Flatwasher, 1/2"
5	04003-806-03	4	Nut, 1/2"-13 Serrated Flange
6	04003-806-04	2	Nut, 5/8"-11 Serrated Flange
7	00113-786-01	1	Angle, Cover Hold-Down
8	00112-540-05	1	Bar, Wiper Backup, 3/8"
9	04003-003-07	4	Bolt, 3/8"-16 x 2" H.H. Gr. 5
10	04004-002-08	4	Flatwasher, 3/8"
11	04003-806-02	4	Nut, 3/8"-16 Serrated Flange
12	00111-987-01	2	Bar, Cover Hold-Down

DECAL GROUP



1. KEEP ALL SHIELDS IN PLACE.
2. MAKE CERTAIN EVERYONE IS CLEAR BEFORE STARTING MACHINE OR MOVING VEHICLE.
3. KEEP HANDS, FEET, AND CLOTHING AWAY FROM ALL POWER DRIVEN PARTS.
4. DISENGAGE PTO, SHUT OFF HYDRAULIC VALVE, AND SET PARKING BRAKE BEFORE LEAVING OPERATORS POSITION. MAKE SURE ALL MOVEMENT HAS STOPPED BEFORE SERVICING, UNCLOGGING, OR CLEANING MACHINE.
5. USE FLASHING LIGHTS WHEN OPERATING MACHINE.
6. MAKE SURE MACHINE IS SOLIDLY SUPPORTED WHEN IT IS BEING MOUNTED, DISMOUNTED, OR STORED.

IF DEFACED - ORDER PART NO. 04049 045 00

NOTE:

DECALS HAVE BEEN SHOWN LARGE ENOUGH SO INFORMATION CAN BE EASILY READ. DECALS ARE NOT PROPORTIONALLY SIZED WITH REFERENCE TO EACH OTHER.



- DO NOT GO UNDER A RAISED LOADED BODY.
- DO NOT GO UNDER A RAISED BODY WITHOUT PROPPING IT. BODY MUST BE EMPTY.
- DURING DUMPING OPERATIONS NO ONE SHALL STAND IN OR MOVE THROUGH THE AREA WHERE THE BODY AND THE HOIST OPERATE OR LOAD MIGHT DISCHARGE.
- OPERATOR MUST REMAIN AT CONTROLS IN CAB DURING DUMPING OPERATIONS.
- DO NOT LEAVE BODY RAISED OR PARTLY RAISED WHILE VEHICLE IS UNATTENDED OR WHILE PERFORMING MAINTENANCE OR SERVICE UNDER BODY UNLESS BODY IS PROPPED TO PREVENT ACCIDENTAL LOWERING.
- ALWAYS DISENGAGE PTO WHEN HOIST IS NOT IN USE OR WHEN MOVING VEHICLE.
- DO NOT ATTEMPT TO RAISE A LOADED BODY WHEN VEHICLE IS ON UNLEVEL GROUND.

IF DEFACED - ORDER PART NO. 04049 321 00

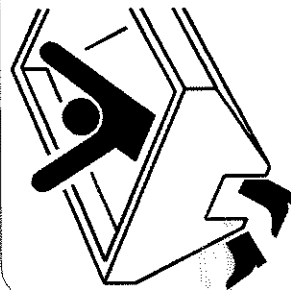

Turn power off before servicing or cleaning

IF DEFACED - ORDER PART NO. 04049 182 00



Stay clear while spinner is turning

IF DEFACED - ORDER PART NO. 04049 044 00



- DO NOT GO UNDER A RAISED LOADED BODY.
- DO NOT GO UNDER A RAISED BODY WITHOUT PROPPING IT - BODY MUST BE EMPTY.
- DO NOT LEAVE RAISED BODY UNATTENDED WITHOUT PROPPING.
- DO NOT POWER DOWN WHILE BODY IS PROPPED. SEE OWNERS MANUAL FOR CORRECT OPERATION OF BODY PROPS.

IF DEFACED - ORDER PART NO. 04049 322 00

DECAL GROUP (CONTINUED)

DANGER
Turn power off before
servicing or cleaning
IF DEFACED - ORDER PART NO. 04049-121-00

DANGER
DO NOT GO UNDER A RAISED LOADED BODY.
DO NOT GO UNDER A RAISED BODY WITHOUT PROPPING IT - BODY MUST BE EMPTY.
DURING DUMPING OPERATIONS NO ONE SHALL STAND IN OR MOVE THROUGH THE AREA WHERE THE BODY AND HOIST OPERATE OR LOAD MIGHT DISCHARGE.
OPERATOR MUST REMAIN AT CONTROLS IN CAB DURING DUMPING OPERATIONS.
DO NOT LEAVE BODY RAISED OR PARTLY RAISED WHILE VEHICLE IS UNATTENDED OR WHILE PERFORMING MAINTENANCE OR SERVICE UNDER BODY UNLESS BODY IS PROPPED TO PREVENT ACCIDENTAL LOWERING.
IF DEFACED - ORDER PART NO. 04049-323-00

OPERATION OF BODY PROP
BODY MUST BE UNLOADED BEFORE USING PROP(S)

TO USE THE PROP(S):
1. RAISE BODY TO HEIGHT WHERE PROP(S) CAN BE SWUNG UPWARD INTO POSITION. PLACE THE HOIST CONTROL VALVE IN THE NEUTRAL (HOLD) POSITION.
2. SWING PROP(S) "UP" INTO SUPPORT POSITION.
3. LOWER BODY SLOWLY UNTIL PROP(S) REST ON BODY PROP RECEIVER. DO NOT POWER HOIST DOWN. PLACE THE HOIST CONTROL VALVE IN THE NEUTRAL (HOLD) POSITION.

TO STORE PROP(S):
4. RAISE BODY TO A HEIGHT WHERE THE PROP(S) WILL CLEAR THE PROP RECEIVER BE SURE THE HOIST CONTROL VALVE IS IN THE NEUTRAL (HOLD) POSITION.
5. SWING PROP(S) DOWN TO TRANSIT POSITION. BEFORE LOWERING BODY, BE CERTAIN THAT THE AREA IS CLEAR.
WHEN TWO PROPS ARE SUPPLIED, BOTH MUST BE USED
[NOTE: BODIES OVER 17' ARE EQUIPPED WITH TWO PROPS]

IF DEFACED - ORDER PART NO. 04049-324-00

Swenson Spreader®
LINDENWOOD ILLINOIS
APB
ALL PURPOSE BODY

Item	Part Number	Qty.	Description
1	04049-045-00	1	General Caution Decal
2	04049-182-00	3	Conveyor Danger Decal
3	04049-044-00	1	Spinner Danger Decal
4	04049-321-00	2	Body General Danger Decal
5	04049-322-00	2	Truck Frame Danger Decal
6	04049-121-00	1	Auger Danger Decal
7	04049-323-00	2	Body General Danger Decal (Small)
8	04049-324-00	2	Body Prop Operation Decal
9	04049-333-00	3	Swenson Logo/APB Decal
.	00112-858-01	.	Decal Package (Consist of items 1-9)

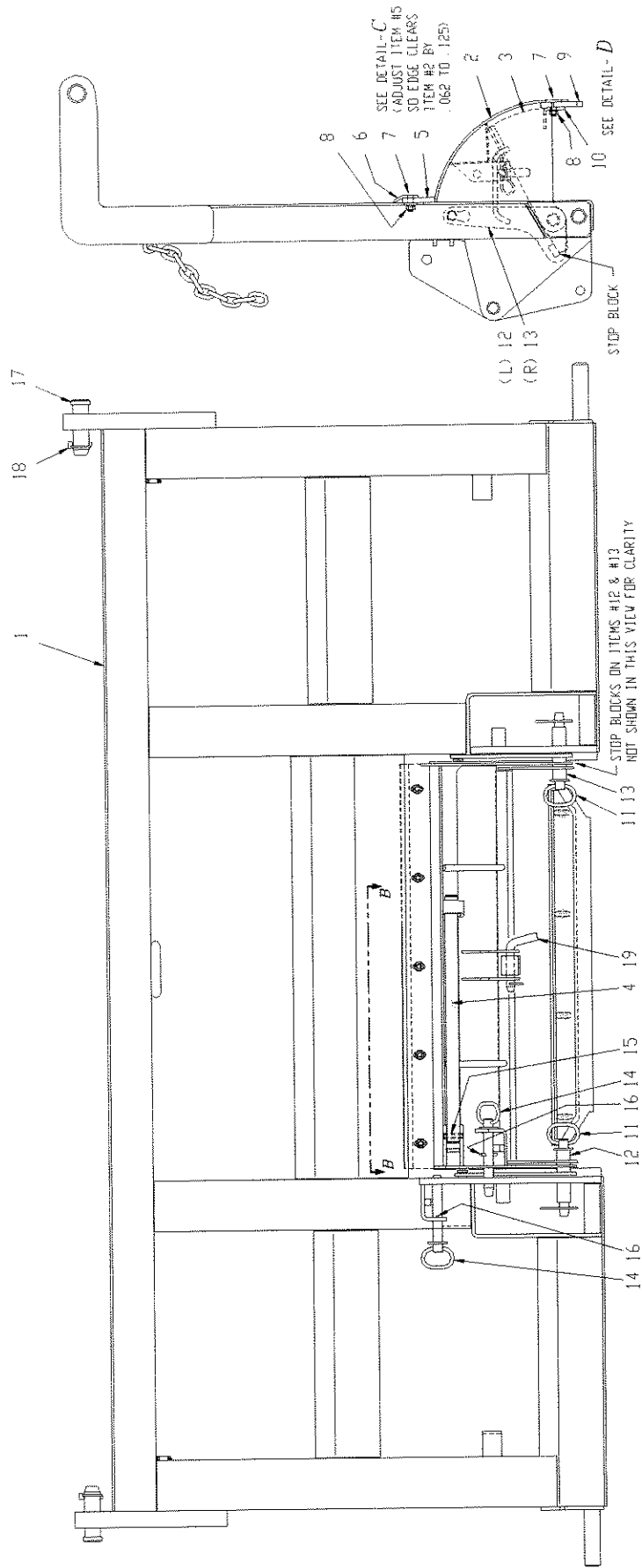

SEE DETAIL - C
(ADJUST ITEM #5
SO EDGE CLEARS
ITEM #2 BY
.062 TO .125)

STOP BLOCK
(L) 12
(R) 13
SEE DETAIL - D

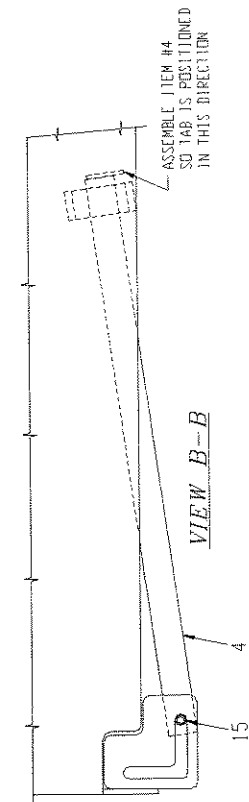
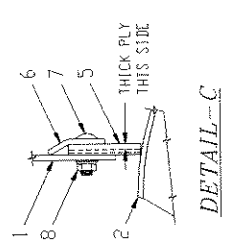
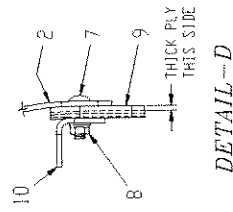

TAILGATE & REVOLVING FEEDGATE ASSEMBLY

TAILGATE & REVOLVING FEEDGATE ASSEMBLY

<u>Item</u>	<u>Part Number</u>	<u>Qty.</u>	<u>Description</u>
1	00112-905-16	1	Weldment, Tailgate (28" Convertible)
	00112-905-19	1	Weldment, Tailgate (36" Convertible)
	00112-905-22	1	Weldment, Tailgate (40" Convertible)
	00112-905-24	1	Weldment, Tailgate (46" Convertible)
2	00112-913-05	1	Weldment, Convertible Feedgate
3	00112-914-01	1	Weldment, Anti-Flow
4	00112-915-03	1	Weldment, Handle
5	04076-082-00	1	Seal, Feedgate
6	00112-906-01	1	Bar, Seal Backup
7	04003-033-04	9	Bolt, 3/8"-16 x 1 1/4" Carriage Gr. 5
8	04003-806-02	9	Nut, 3/8"-16 Serrated Flange
9	04076-083-00	1	Wiper, Rear Feedgate
10	00112-395-01	1	Angle, Gate Backup
11	04014-101-01	2	Pin, 3/4" Hitch Keeper
12	00114-517-01	1	Weldment, Left Arm
13	00114-518-01	1	Weldment, Right Arm
14	04014-101-05	2	Pin, Hitch (Reworked)
15	04016-008-01	1	Pin, 3/8" x 1 1/2" Roll
16	04012-001-03	2	Pin, 3/16" x 1 3/4" Grooved
17	00112-529-00	2	Pin, Hinge
18	04014-201-01	2	Pin, Linch
19	04014-150-01	1	Pin, Bent Hitch w/Keeper

Note: Part numbers shown are for standard carbon steel units, for materials other than carbon steel contact your dealer.

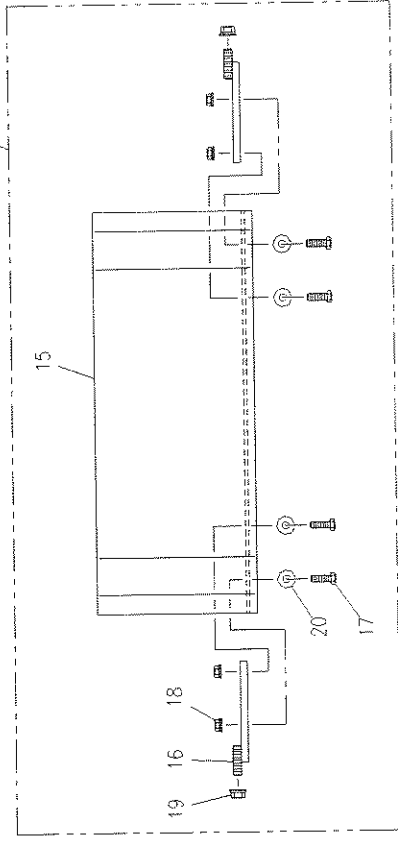
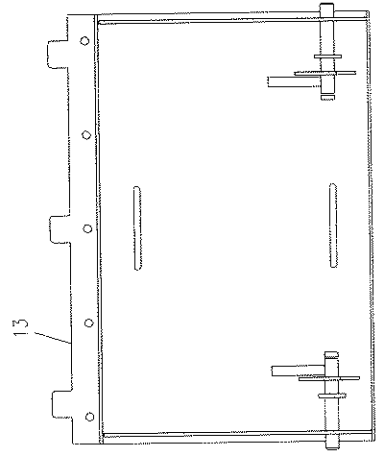
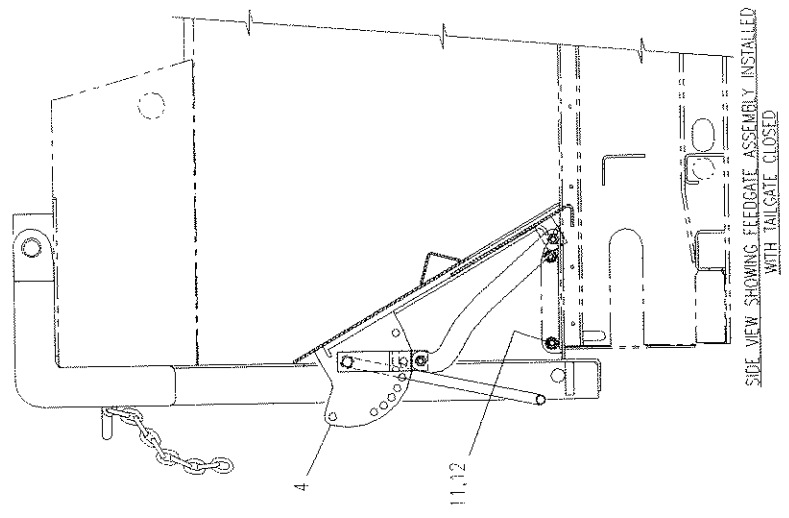
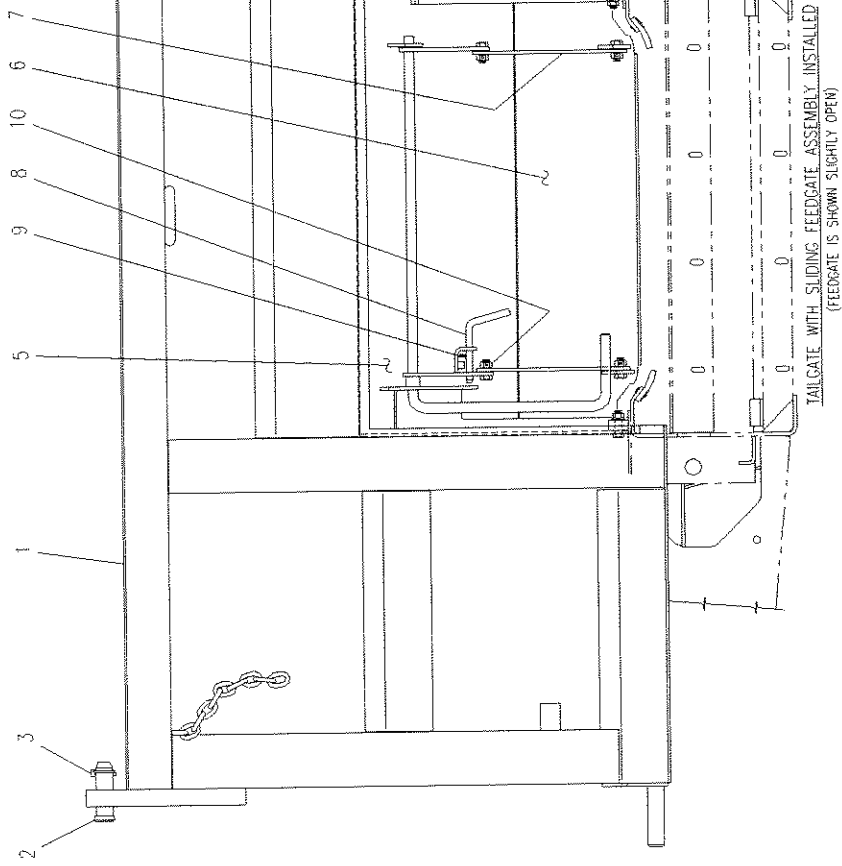

TAILGATE & SLIDING FEEDGATE ASSEMBLY
 (INCLUDING FILL PLATE AND STUB CONVEYOR COVER)

TAILGATE & SLIDING FEEDGATE ASSEMBLY

(Including Fill Plate and Stub Conveyor Cover)

<u>Item</u>	<u>Part Number</u>	<u>Qty.</u>	<u>Description</u>
1	00112-905-51	1	Weldment, Tailgate 20" S/F (20" Side Height) Mid Size
	00112-905-54	1	Weldment, Tailgate 28" S/F (28" Side Height)
	00112-905-56	1	Weldment, Tailgate 36" S/F (36" Side Height)
	00112-905-57	1	Weldment, Tailgate 40" S/F (40" Side Height)
	00112-905-58	1	Weldment, Tailgate 46" S/F (46" Side Height)
2	00112-529-00	2	Pin, Hinge
3	04014-201-01	2	Pin, Linch
4	00114-875-01	1	Assembly, Feedgate Housing (Includes Items 5-10)
5	00115-857-01	1	Weldment, Feedgate Housing
6	00115-868-01	1	Weldment, Feedgate
7	00115-877-01	2	Bar, Long Linkage
8	04014-150-03	1	Pin, Bent (Stainless Steel)
9	04016-004-01	1	Pin, 3/16" x 1" Roll
10	04003-807-11	4	Locknut, 1/2"-13 Cen. Lock
11	04003-005-35	4	Bolt, 1/2"-13 x 1 3/4" H.H. Gr. 5
12	04003-806-03	4	Nut, 1/2"-13 Serrated Flange
13	00115-871-01	1	Weldment, Fill Plate
14	00002-340-01	1	Kit, Stub Conveyor Cover (Includes Items 15-20)
15	00115-884-01	1	Weldment, Stub Cover
16	00113-784-01	2	Weldment, Bolting Bar
17	04003-005-05	4	Bolt, 1/2"-13 x 1 1/2" H.H. Gr. 5
18	04003-806-03	4	Nut, 1/2"-13 Serrated Flange
19	04003-806-04	2	Nut, 5/8"-11 Serrated Flange
20	04004-002-10	4	Flatwasher, 1/2"

TAILGATE LATCH ASSEMBLY
(MID SIZE APB)

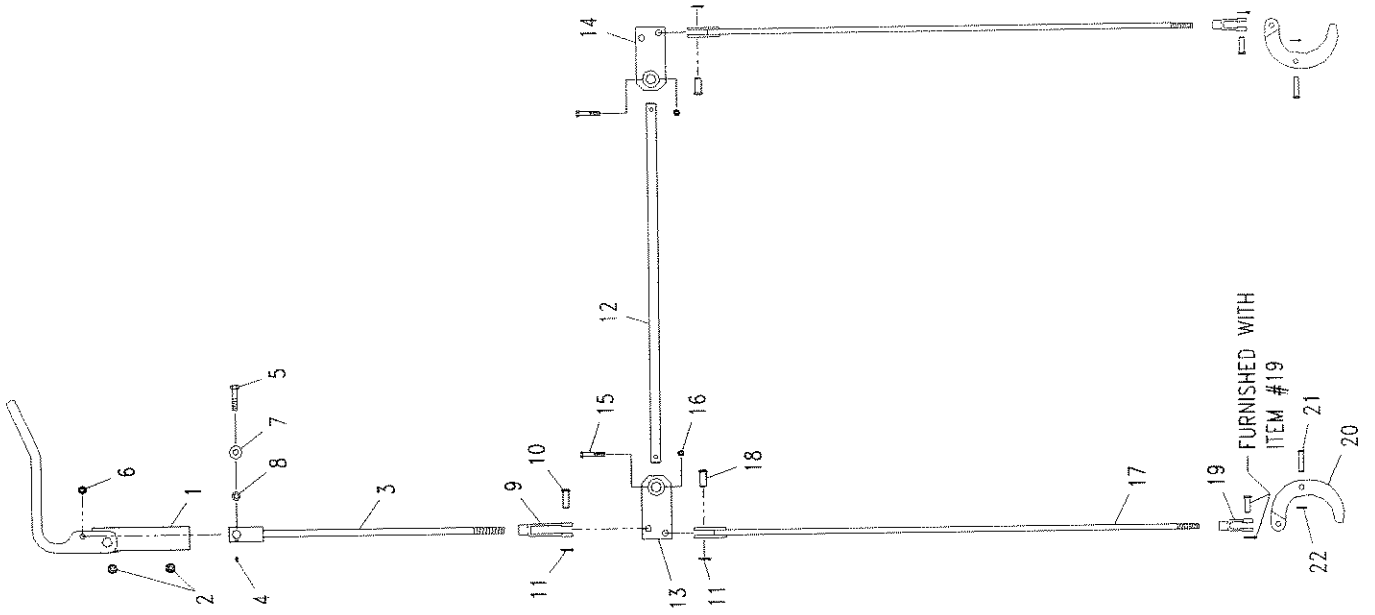

TAILGATE LATCH ASSEMBLY
(FULL SIZE APB)

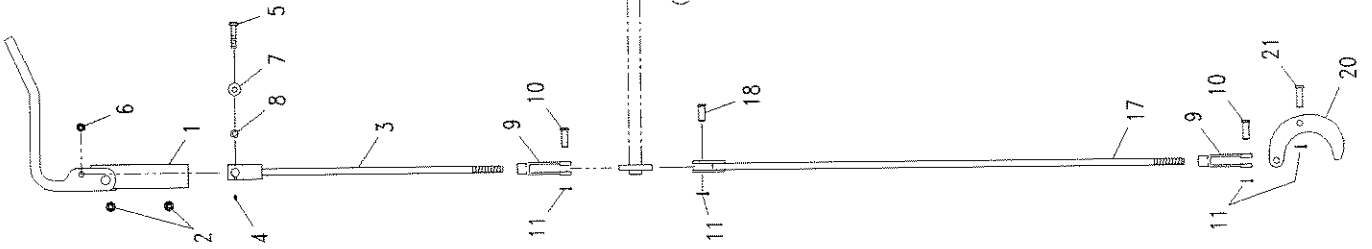
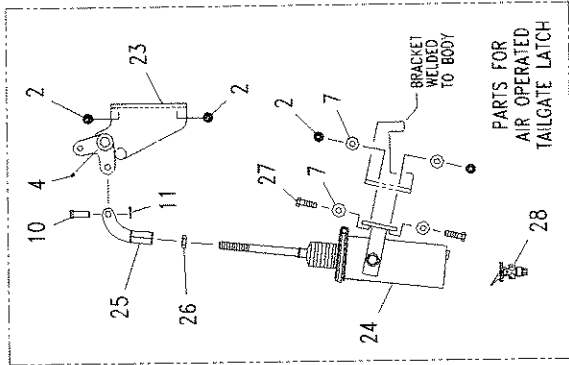

TAILGATE LATCH ASSEMBLY

(Full Size and Mid Size Manual and Air Operated)

<u>Item</u>	<u>Part Number</u>	<u>Qty.</u>	<u>Description</u>
1	00112-536-01	1	Weldment, Latch Handle
2	04003-806-03	2/4*	Nut, 1/2"-13 Serrated Flange
3	00112-518-01	1	Weldment, Short Rod
4	04015-005-00	1/2*	Fitting, Straight Grease
5	04003-005-42	1	Bolt, 1/2"-13 x 2 1/4" H.H. Gr. 5
6	04003-807-11	1	Locknut, 1/2"-13 Center Lock
7	04004-002-10	1/5*	Flatwasher, 1/2"
8	04008-005-00	1	Bushing, Spacer
9	04096-003-00	1	End, Yoke
10	04014-008-02	2/3*	Pin, 5/8" x 1 3/4" Clevis
11	04010-004-03	3/4*	Pin, 5/32" x 1 1/4" Cotter
12	00112-535-01	1	Rod, Latch Pivot
13	00112-521-01	1	Weldment, Left Latch Arm
14	00112-522-01	1	Weldment, Right Latch Arm
15	04003-003-45	2	Bolt, 3/8"-16 x 2 1/4" H.H. Gr. 8
16	04003-807-09	2	Locknut, 3/8"-16 Center Lock
17	00116-773-01	2	Weldment, Long Rod (8' Body Length) (Full Size)
	00116-773-02	2	Weldment, Long Rod (9' Body Length) (Full Size)
	00116-773-04	2	Weldment, Long Rod (10' Body Length) (Full Size)
	00116-773-05	2	Weldment, Long Rod (11' Body Length) (Full Size)
	00116-773-06	2	Weldment, Long Rod (12' Body Length) (Full Size)
	00116-773-07	2	Weldment, Long Rod (13' Body Length) (Full Size)
	00116-773-08	2	Weldment, Long Rod (14' Body Length) (Full Size)
	00116-773-09	2	Weldment, Long Rod (15' Body Length) (Full Size)
	00116-773-10	2	Weldment, Long Rod (16' Body Length) (Full Size)
	00116-773-11	2	Weldment, Long Rod (17' Body Length) (Full Size)
	00116-773-12	2	Weldment, Long Rod (18' Body Length) (Full Size)
	00112-515-11	2	Weldment, Long Rod (7' Body Length) (Mid Size)
	00112-515-05	2	Weldment, Long Rod (8' Body Length) (Mid Size)
	00112-515-02	2	Weldment, Long Rod (9' Body Length) (Mid Size)
	00112-515-01	2	Weldment, Long Rod (10' Body Length) (Mid Size)
	00112-515-07	2	Weldment, Long Rod (11' Body Length) (Mid Size)
18	04014-008-04	2	Pin, 5/8" x 1 1/2" Clevis
19	04096-011-00	2	End, Yoke (w/Clevis Pin and Cotter Pin)
20	00116-775-00	2	Hook, Latch (Full Size)
	00112-825-01	2	Hook, Latch (Mid Size)
21	04014-008-03	2	Pin, 5/8" x 2" Clevis (Full Size)
	04014-004-03	2	Pin, 1/2" x 2" Clevis (Mid Size)
22	04014-004-03	2	Pin, 1/8" x 1" Cotter
23	00114-304-01	0/1*	Weld, Latch Crank
24	04108-004-00	0/1*	Kit, Air Cylinder (Spring Brake)
25	00114-307-01	0/1*	Weld, Yoke
26	04003-802-13	0/1*	Nut, 3/4"-16 Hex Jam ZP
27	04003-005-35	0/2*	Bolt, 1/2"-13 X 1 3/4" HH Gr. 5 ZP
28	04105-338-00	0/1*	Valve, Air Control (Cab Mounted)

Note: Part numbers shown are for standard carbon steel units, for materials other than carbon steel contact your dealer.

***X/X First number is qty for manual tailgate latch assembly,
Second is for air operated tailgate latch assembly.**

FRONT SPINNER ASSEMBLY

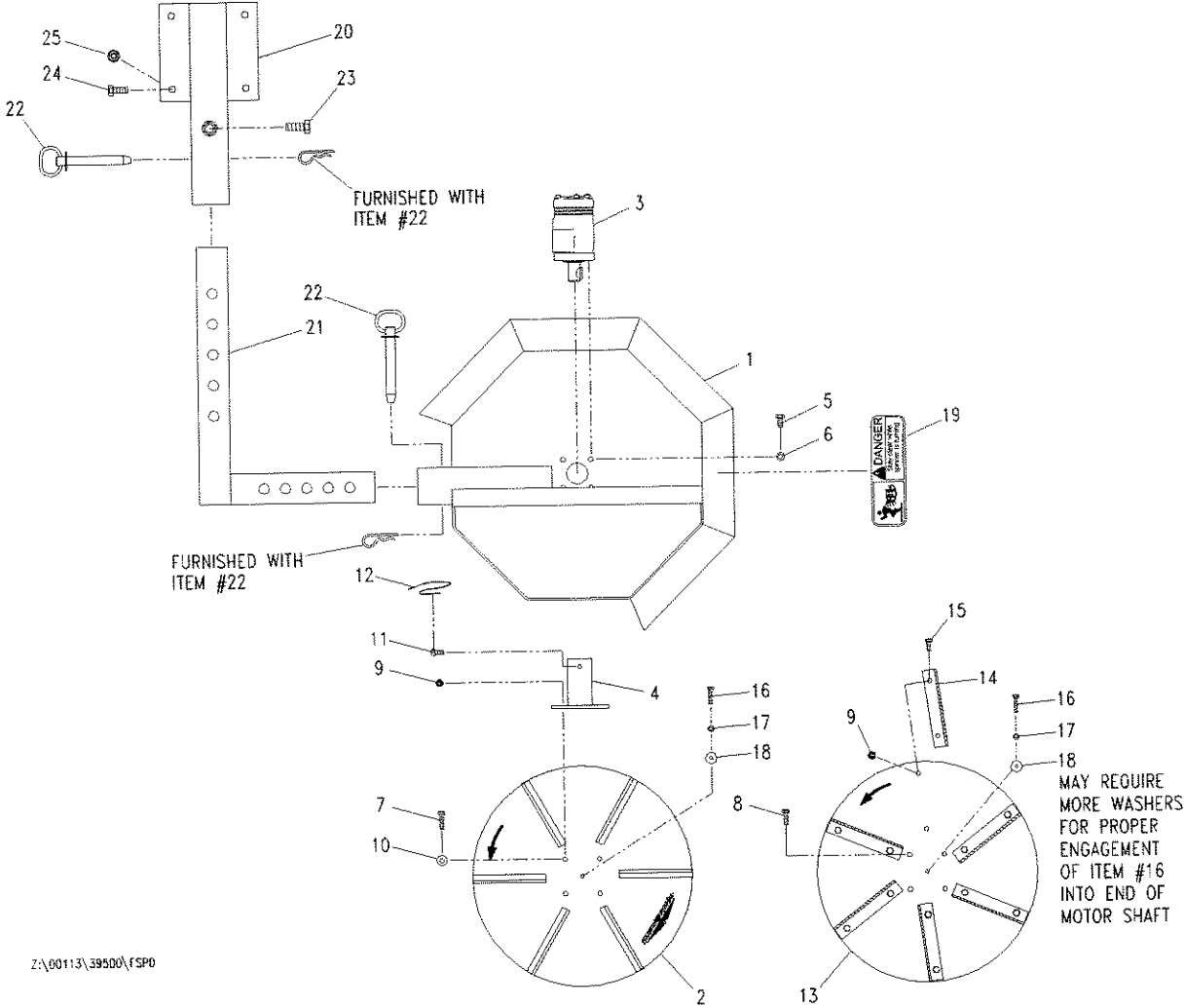

Z:\00113\39500\FSPD

Polyurethane Spinner Disc

Steel Spinner Disc

FRONT SPINNER ASSEMBLY

<u>Item</u>	<u>Part Number</u>	<u>Qty.</u>	<u>Description</u>
1	00112-486-01	1	Weldment, Spinner Frame
2	04622-002-00	1/0*	Disc, Polyurethane Spinner (18")
3	04101-035-00	1	Motor, Hydraulic
4	00109-218-00	1	Weldment, Spinner Hub
5	04003-003-01	4	Bolt, 3/8"-16 x 3/4" H.H. Gr. 5
6	04004-001-07	4	Lockwasher, 3/8"
7	04003-002-05	4/0*	Bolt, 5/16"-18 x 1 1/4" H.H. Gr. 5
8	04003-002-04	0/4*	Bolt, 5/16"-18 x 1" H.H. Gr. 5
9	04003-806-01	4/16*	Nut, 5/16"-18 Serrated Flange
10	04004-002-07	4/0*	Flatwasher, 5/16"
11	04006-008-01	1	Setscrew, 3/8" x 3/4" Sq. Head
12	06020-000-00	.833 ft.	Wire, Safety
13	06008-000-00	0/1*	Disc, Spinner (18", 7 ga. steel)
14	06009-008-00	0/6*	Flite, Spinner (7 ga. steel)
15	04003-002-02	0/12*	Bolt, 5/16"-18 x 3/4" H.H. Gr. 5
16	04003-001-27	1	Bolt, 1/4"-20 x 3 1/2" H.H. S.S.
17	04004-001-05	1	Lockwasher, 1/4"
18	04004-002-06	1	Flatwasher, 1/4"
19	04049-044-00	1/4*	Decal, Danger (Spinner)
20	00112-485-01	1	Weldment, Outer Tube
21	00112-484-01	1	Weldment, Inner Tube
22	04014-101-01	2	Pin, 3/4" Hitch (w/keeper)
23	04003-006-03	1	Bolt, 5/8"-11 x 1 1/2" H.H. Gr. 5
24	04003-005-05	4	Bolt, 1/2"-13 x 1 1/2" H. H. Gr. 5
25	04003-806-03	4	Nut, 1/2"-13 Serrated Flange

***X/X - First number is quantity for units with polyurethane spinner disc,
second number is quantity for units with steel spinner disc.**

**Note: Part numbers shown are for standard carbon steel units, for materials
other than carbon steel, contact your dealer.**

REAR SPINNER ASSEMBLY

(Bolted-on & Hinged Spinner Chute)
 (Fixed Baffle & Adjustable Baffle Spinner Frame)

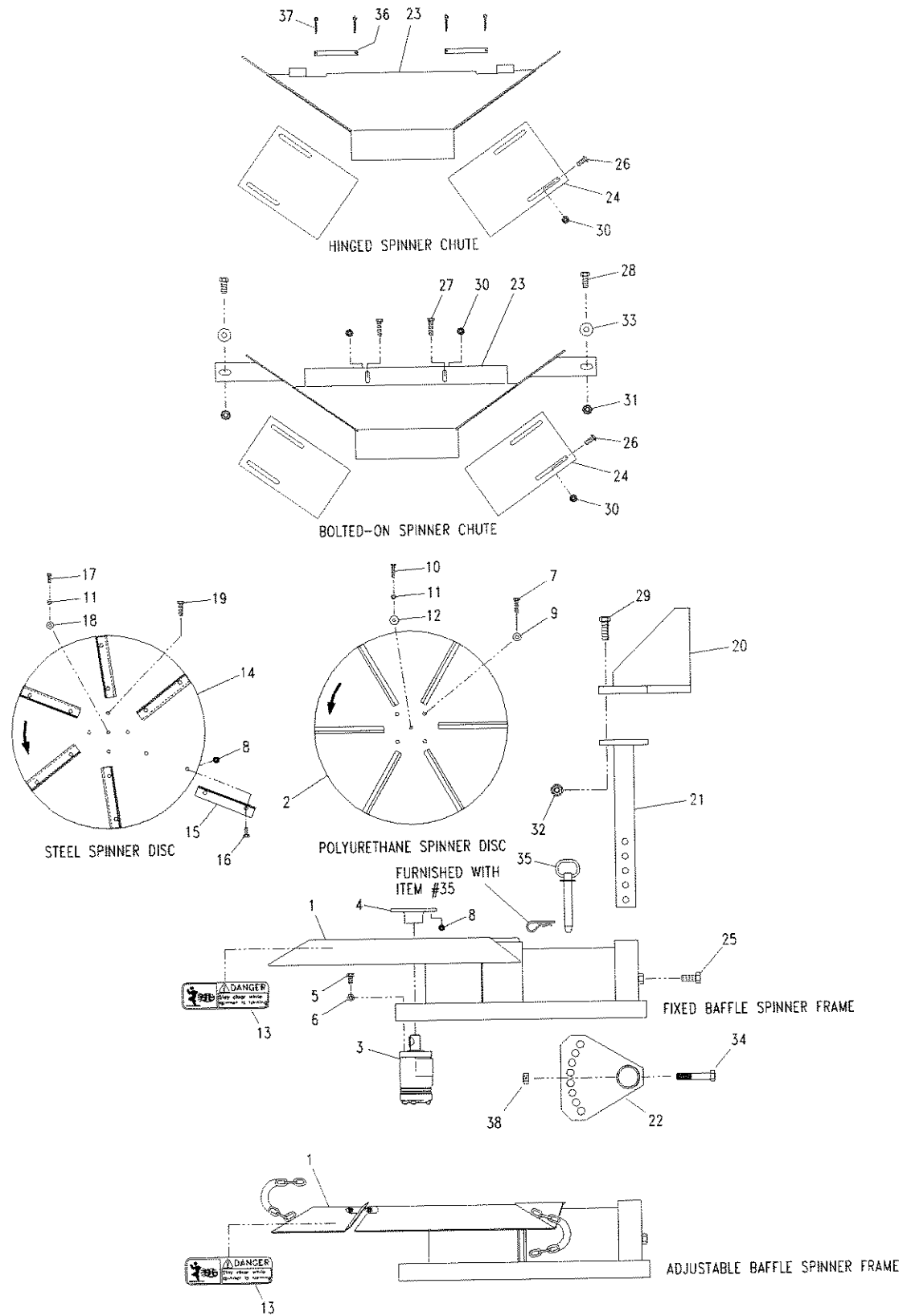

REAR SPINNER ASSEMBLY

(Bolted-on & Hinged Spinner Chute)
(Fixed Baffle & Adjustable Baffle Spinner Frame)

<u>Item</u>	<u>Part Number</u>	<u>Qty.</u>	<u>Description</u>
1	00113-000-01	1	Weldment, Spinner Frame (Fixed Baffle)
	00113-000-03	1	Weldment, Spinner Frame (Adjustable Baffle)
2	04622-007-00	1/0*	Disc, Polyurethane Spinner (20")
3	04101-035-00	1	Motor, Hydraulic
4	06012-003-00	1	Machining, Spinner Hub
5	04003-003-01	4	Bolt, 3/8"-16 x 3/4" H.H. Gr. 5
6	04004-001-07	4	Lockwasher, 3/8" Med. Split
7	04003-002-05	4/0*	Bolt, 5/16" x 1 1/4" H.H. Gr. 5
8	04003-806-01	4/16*	Nut, 5/16"-18 Serrated Flange
9	04004-002-07	4/0*	Flatwasher, 5/16"
10	04003-001-17	1/0*	Bolt, 1/4"-20 X 1 1/4" H. H.
11	04004-001-05	1	Lockwasher, 1/4" Med. Split
12	04004-002-38	1	Washer, Backup
13	04049-044-00	1	Decal, Danger (Spinner)
14	00105-505-00	0/1*	Disc, Spinner (20", 10 ga.)
15	06009-008-00	0/6*	Flite, Spinner (7 ga.)
16	04003-002-02	0/12*	Bolt, 5/16"-18 x 3/4" H.H. Gr. 5
17	04003-001-11	0/1*	Bolt, 1/4"-20 x 3/4" H.H.
18	04004-002-05	0/1*	Flatwasher, 1/4"
19	04003-002-04	0/4*	Bolt, 5/16"-18 x 1" H.H. Gr. 5
20	00112-997-01	1	Weldment, Post Mount
21	00112-999-01	1	Weldment, Post
22	00112-998-01	1	Weldment, Adjustment Plate
23	00113-264-01	1	Weldment, Chute (Bolted-On)
	00115-672-01	1	Weldment, Chute (Hinged)
24	00112-990-01	2	Plate, Adjustable (For Bolted-On Spinner Chute)
	00115-675-01	2	Plate, Adjustable (For Hinged Spinner Chute)
25	04003-006-03	1	Bolt, 5/8"-11 x 1 1/2" H.H. Gr. 5
26	04003-033-09	4	Bolt, 3/8"-16 x 1" Carriage Gr. 5
27	04003-003-05	2	Bolt, 3/8"-16 x 1 1/2" H. H. Gr. 5
28	04003-005-02	2	Bolt, 1/2"-13 x 1 1/4" H. H. Gr. 5
29	04003-006-02	4	Bolt, 5/8"-11 x 2" H. H. Gr. 5
30	04003-806-02	6	Nut, 3/8"-16 Serrated Flange
31	04003-806-03	2	Nut, 1/2"-13 Serrated Flange
32	04003-806-04	4	Nut, 5/8"-11 Serrated Flange
33	04004-002-10	2	Flatwasher, 1/2"
34	04003-006-26	1	Bolt, 5/8"-11 x 3 1/2" H.H. Gr. 5
35	04014-101-01	1	Pin, 3/4" Hitch (w/keeper)
36	04014-102-03	2	Pin, Headless, S.S. (For Hinged Spinner Chute)
37	04010-015-02	4	Pin, 5/32" x 1 1/4" Cotter
38	04003-807-12	1	Locknut, 5/8"-11 Hex

FRONT CROSS AUGER ASSEMBLY

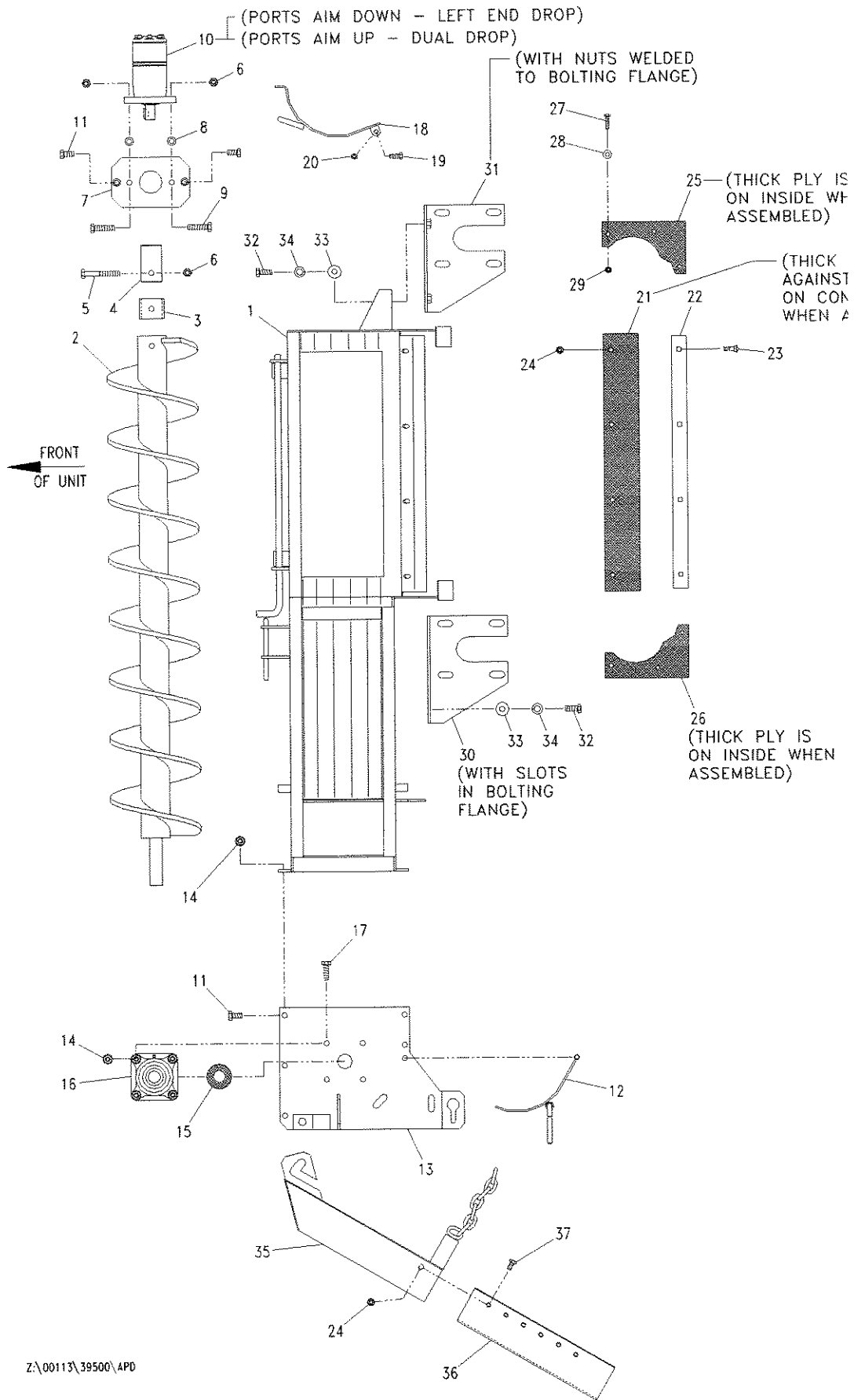

Z:\00113\39500\APD

FRONT CROSS AUGER ASSEMBLY

(Single Left End Drop and Dual Drop)

<u>Item</u>	<u>Part Number</u>	<u>Qty.</u>	<u>Description</u>
1	00112-819-01	1	Weldment, Trough
	00112-819-03	1	Weldment, Trough (Dual Dropout)
2	00112-817-01	1	Weldment, Auger
	00112-817-02	1	Weldment, Auger (Dual Dropout)
3	00111-294-00	1	Insert, Auger
4	00112-413-01	1	Sleeve, Drive
5	04003-005-43	1	Bolt, 1/2"-13 x 3 1/2" H.H. Gr. 8
6	04003-807-11	3	Locknut, 1/2"-13
7	00112-824-01	1	Weldment, Mounting Plate
8	04008-005-00	2	Bushing Spacer
9	04003-005-07	2	Bolt, 1/2"-13 x 2" H.H. Gr. 5
10	04101-101-00	1	Motor, Hydraulic
11	04003-005-01	7/12	Bolt, 1/2"-13 x 1" H.H. Gr. 5
12	00112-526-01	1/2	Weldment, Salt Plate
13	00112-820-01	1/2	Weldment, Endplate
14	04003-806-03	9/14	Nut, 1/2"-13 Serrated Flange
15	04005-002-00	1	Washer, 1 1/4" Felt
16	04080-003-00	1	Bearing, 1 1/4"
17	04003-005-05	4	Bolt, 1/2"-13 x 1 1/2" H.H. Gr. 5
18	00112-821-01	1	Weldment, Bottom Door
19	04003-003-03	2	Bolt, 3/8"-16 x 1" H.H. Gr. 5
20	04003-804-02	2	Locknut, 3/8"-16 Nylon Insert
21	04076-072-00	1	Wiper, Cross Auger
22	00112-804-01	1	Bar, Wiper Backup
23	04003-033-04	4	Bolt, 3/8"-16 x 1 1/4" Carriage Gr. 5
24	04003-806-02	6/8	Nut, 3/8"-16 Serrated Flange
25	04076-074-00	1	Seal, Right Front
26	04076-075-00	1	Seal, Left Front
27	04003-002-04	6	Bolt, 5/16"-18 x 1" H.H. Gr. 5
28	04004-002-07	6	Flatwasher, 5/16"
29	04003-806-01	6	Nut, 5/16"-18 Serrated Flange
30	00112-469-01	1	Bracket, Left Mounting
31	00112-818-01	1/0	Weldment, Right Mounting Bracket (Left End Drop)
	00114-873-01	1/0	Bracket, Right Mounting (Dual Dropout)
32	04003-005-02	4	Bolt, 1/2"-13 x 1 1/4" H.H. Gr. 5
33	04004-002-10	4	Flatwasher, 1/2"-13
34	04004-001-09	4	Lockwasher, 1/2"
35	00112-487-01	1/2	Weldment, Chute
36	00112-482-01	1/2	Chute, Extension
37	04003-003-01	2/4	Bolt, 3/8"-16 x 3/4" H.H. Gr. 5

*X/X - First number is quantity for units with left end dropout only,
Second number is quantity for units with left end and right end dropout.

Note: Part numbers shown are for standard carbon steel units, for materials other than carbon steel, contact your dealer.

STANDARD PARTS AVAILABLE FOR HYDRAULIC MOTORS

<u>Part Number</u>	<u>Qty.</u>	<u>Description</u>
04101-136-01	1	Seal Kit for "White" Conveyor Hydraulic Motor (127.69 C.I.D./Rev.) (Swenson Motor No. 04101-136-00)
04101-124-04	1	Seal Kit for "White" Spinner Hydraulic Motor (3.2 C.I.D./Rev.) (Swenson Motor No. 04101-035-00)
04101-102-09	1	Seal Kit for "Eaton/Char-Lynn" Crossauger Hydraulic Motor (22.6 C.I.D./Rev.) (Swenson Motor No. 04101-101-00)

LIFT-IN/LIFT-OUT TOP SCREENS

(See page 61 for parts list.)

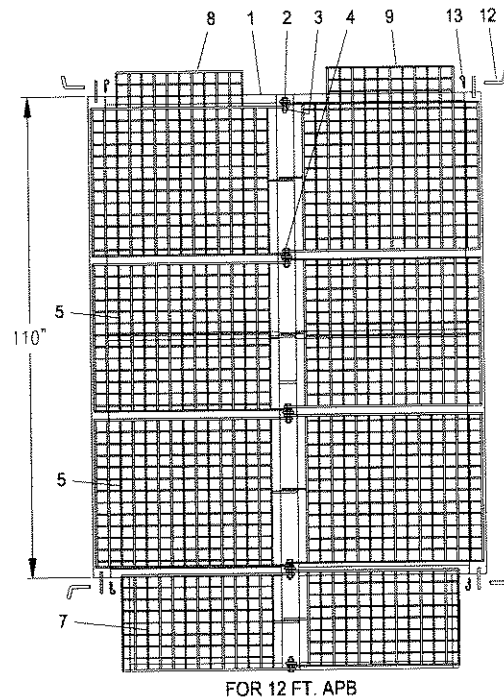
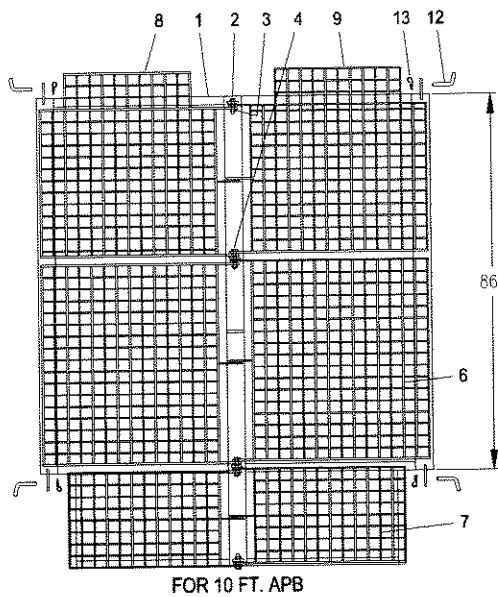
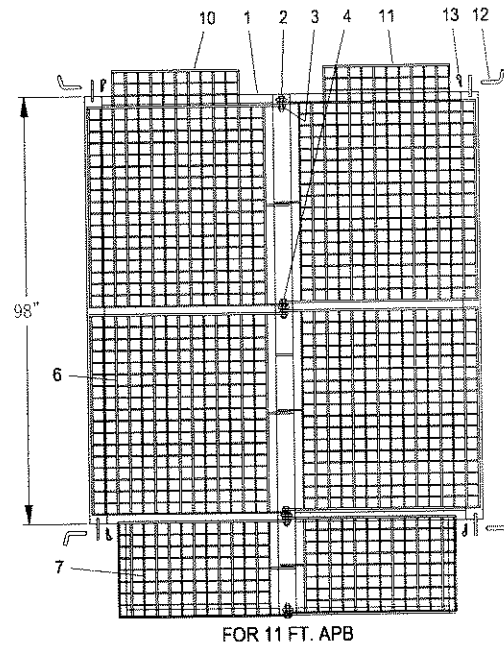
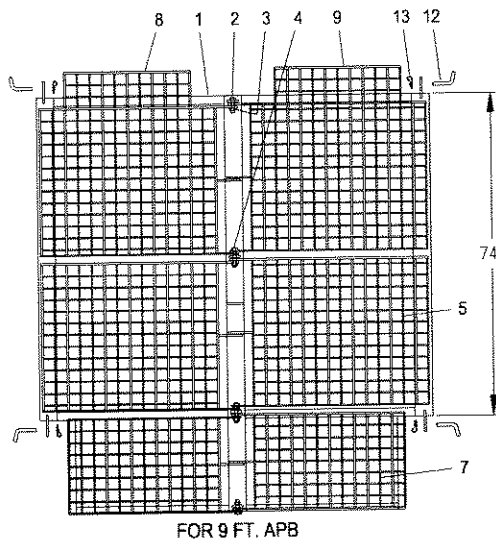

Z:\00113\39500\SCREENSA

DANGER!

SERIOUS PERSONAL INJURY CAN RESULT BY CLIMBING INTO AN OPERATING DUMP BODY. STAY OUT OF DUMP BODY WHEN TRUCK ENGINE IS OPERATING.

INDIVIDUAL TOP SCREENS (AS SHOWN ON PAGES 59, 60 AND 61) ARE NOT INTENDED TO BE LIFTED AND HINGED OVER.

BEFORE TOP SCREENS CAN BE LIFTED VERY FAR, THE CENTER SUPPORT BAR ON THE SCREEN WILL STRIKE THE CENTER I-BEAM SUPPORT RESTRICTING THE OPENING FOR ACCESS TO THE INSIDE OF BODY.

LIFT-IN/LIFT-OUT TOP SCREENS

(See page 61 for parts list.)

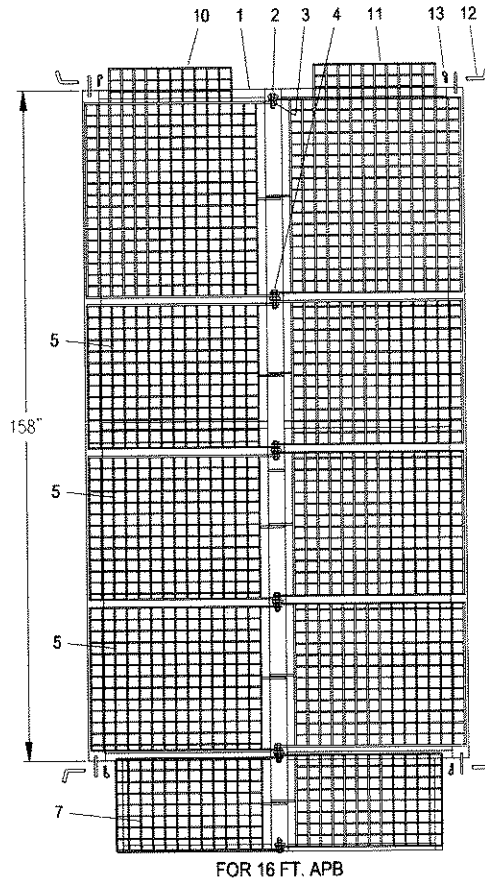
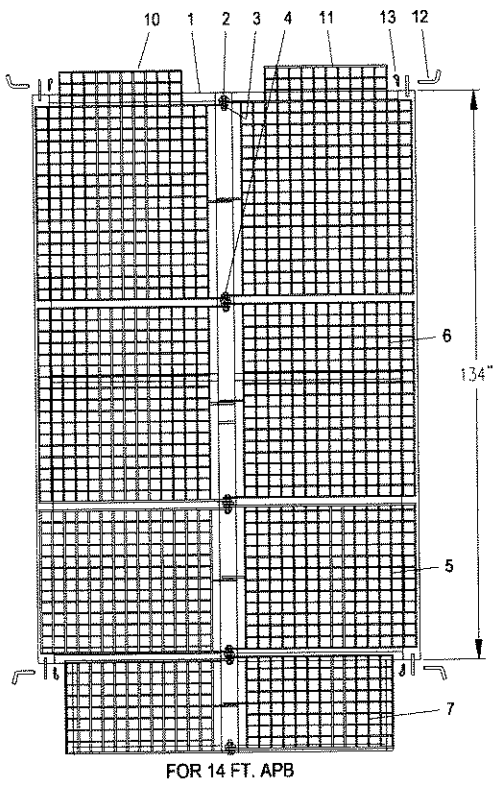
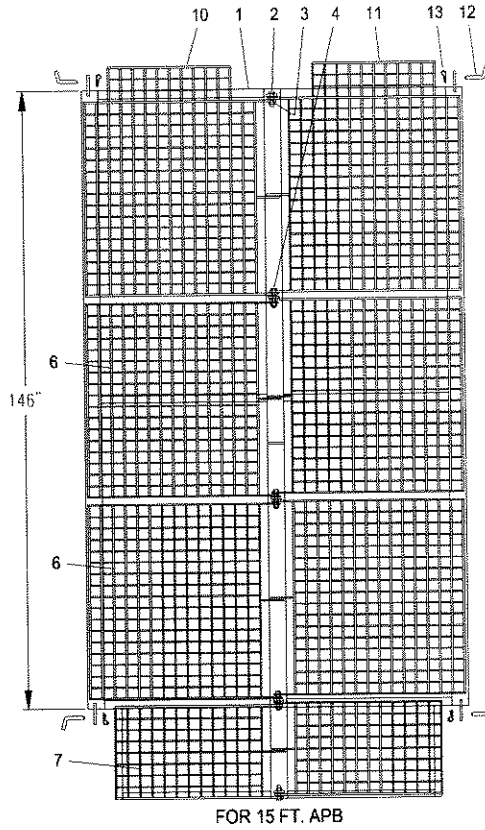
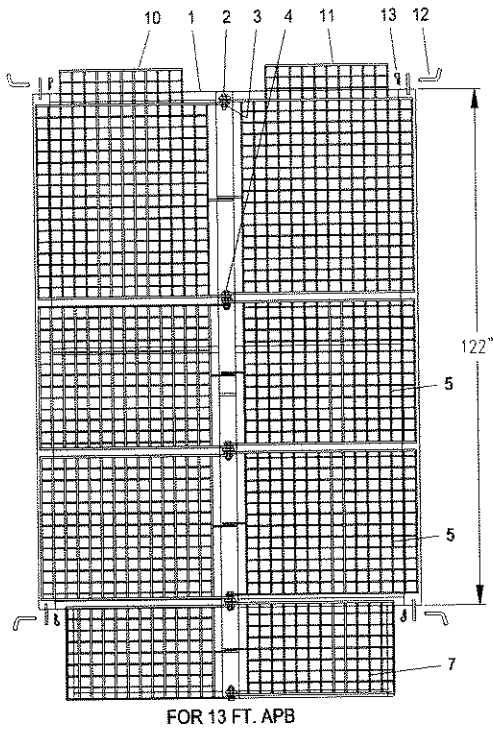

Z:\00113\39500\SCREENSB

LIFT-IN/LIFT-OUT TOP SCREENS

(Continued)

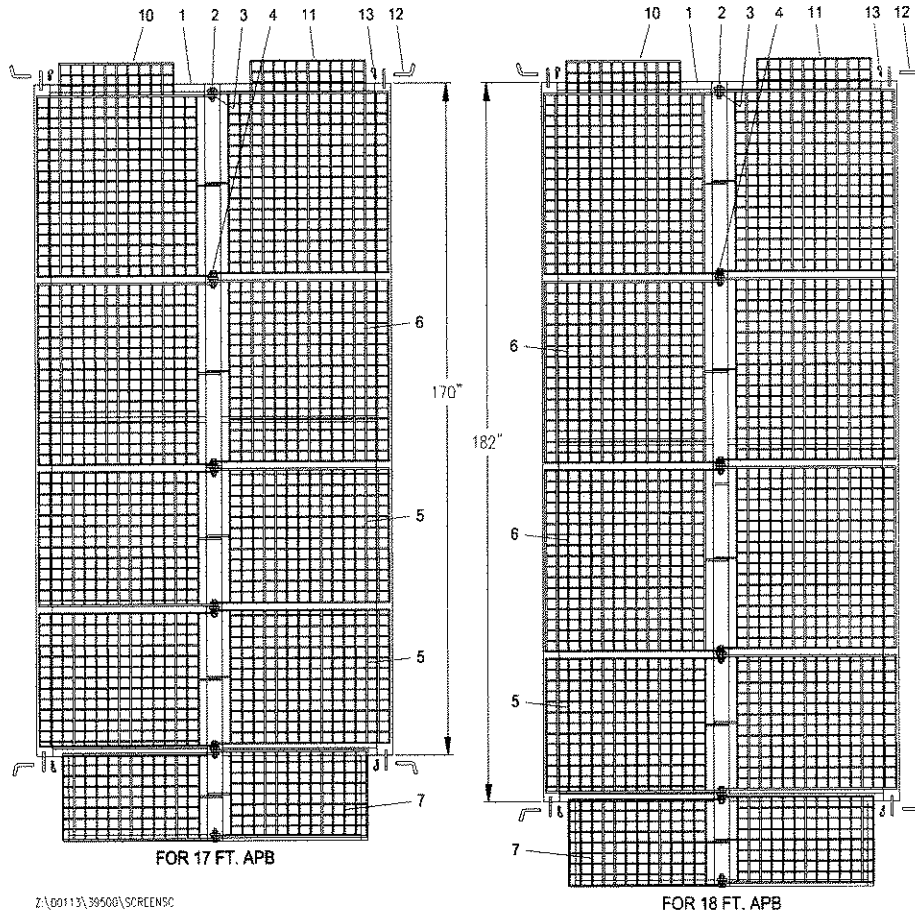

PARTS LIST

<u>Item</u>	<u>Part Number</u>	<u>Qty.</u>	<u>Description</u>	
1	00116-936-02	1	Weldment, Screen Frame, 9 Ft.	
	00116-936-03	1	Weldment, Screen Frame, 10 Ft.	
	00116-936-04	1	Weldment, Screen Frame, 11 Ft.	
	00116-936-05	1	Weldment, Screen Frame, 12 Ft.	
	00116-936-06	1	Weldment, Screen Frame, 13 Ft.	
	00116-936-07	1	Weldment, Screen Frame, 14 Ft.	
	00116-936-08	1	Weldment, Screen Frame, 15 Ft.	
	00116-936-09	1	Weldment, Screen Frame, 16 Ft.	
	00116-936-10	1	Weldment, Screen Frame, 17 Ft.	
	00116-936-11	1	Weldment, Screen Frame, 18 Ft.	
	2	04003-007-04	2	Bolt, 3/4-10 X 2 1/2 HH GR 5, ZP
	3	04003-807-13	A/N	Locknut, 3/4-10 Top Lock ZP
	4	04003-007-02	A/N	Bolt, 3/4-10 X 3 1/2 HH GR 5, ZP
5	00116-781-01	A/N	Weldment, 3 Ft. Screen Weld	
6	00116-782-01	A/N	Weld, 4 Ft. Screen Weld	
7	00117-408-01	2	Weldment, Rear Fill Screen	
8	00117-415-01	1	Weldment, Left Front 3 Ft. Screen	
9	00117-416-01	1	Weldment, Right Front 3 Ft. Screen	
10	00117-417-01	1	Weldment, Left Front 4 Ft. Screen	
11	00117-418-01	1	Weldment, Right Front 4 Ft. Screen	
12	04014-150-06	4	Pin, Bent (Stainless Steel)	
13	04011-001-04	4	Keeper, Hairpin (Stainless Steel)	

A/N = As needed depending upon length of your unit. (Specify quantity when ordering.)

SERIAL NUMBER DECAL INFORMATION

- When ordering parts or requesting information or assistance, always include the information listed below.
- The description, part number, and serial number for the spreader is shown on the serial number decal.
- The space below is provided as a convenient place to record these numbers; just fill in the blanks.

DESCRIPTION _____

PART NUMBER _____

SERIAL NUMBER _____

DATE PURCHASED _____

PURCHASED FROM _____

DEALER'S SERVICE DEPARTMENT PHONE NUMBER

EXPLANATION OF SERIAL NUMBER DECAL

NOTE: Numbers shown on decal below are for example purposes only. Refer to decal on spreader for recording numbers above.

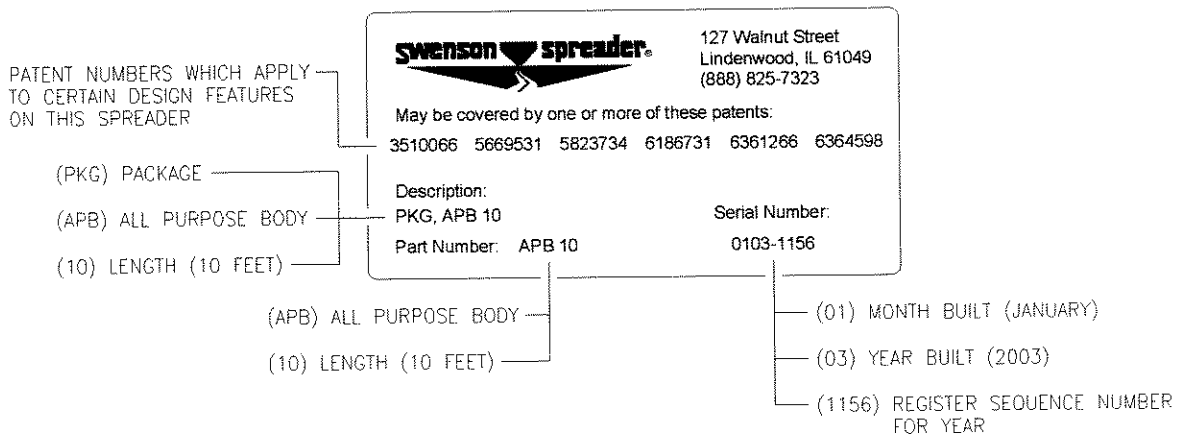

Z:\00111\00111-389-00RTJPD

CALL YOUR AUTHORIZED SWENSON SPREADER DEALER FOR PARTS AND SERVICE
SWENSON SPREADER (815) 393-4455
TOLL FREE (888) 825-7323
FAX (866) 310-0300
email: swensonsales@swensonspreader.com



Dealers have the responsibility of calling to the attention of their customers the following warranty prior to acceptance of an order from that customer for any SWENSON® product.

WARRANTY

WHAT THIS WARRANTY COVERS

Swenson Spreader LLC (hereinafter "Swenson") is committed to assuring Customer satisfaction with the Spreader (hereinafter "Product"). Swenson warrants to the original owner (hereinafter "Purchaser") of the Product to be free from defects in material and workmanship for the following term: Swenson warrants ALL PARTS AND ASSEMBLIES to be free from defects in material and workmanship for a period of one year from the date of purchase. Installation of the Product must be in accordance with Swenson's instructions. This warranty extends to the Purchaser and may not be assigned without the prior written approval of Swenson; except a distributor may assign this warranty to the first titled owner of the Product.

If a Product has a defect in material or workmanship covered by the warranty, Swenson will (at our option) either replace or repair said part. Swenson's has sole discretion as to repair of defects covered by this warranty, or replacement of the Product. Swenson's responsibilities as described herein shall not exceed the amount of the purchase of the Product.

WHAT THIS WARRANTY DOES NOT COVER

Swenson's warranty does not extend to Product which have been misused, abused, improperly installed, repaired with non-genuine Swenson parts, improperly cared for, if materials such as lava rock or cinders are used, or for which payment has not been made. The warranty is void if repairs or alterations to the Product are made by unauthorized persons, or the Product serial numbers have been altered or defaced.

All gasoline engines and hydraulic pumps are warranted by their manufacturer and not by Swenson Spreader LLC. Electrical or hydraulic components are not to be disassembled without the express written permission of Swenson Spreader LLC.

THERE ARE NO WARRANTIES, EXPRESS OR IMPLIED, WHICH EXTEND BEYOND THE DESCRIPTION ON THE FACE HEREOF. THERE IS NO IMPLIED WARRANTY OF MERCHANTABILITY OR FITNESS FOR A PARTICULAR PURPOSE. SWENSON'S MAXIMUM OBLIGATION AND LIABILITY UNDER THIS WARRANTY SHALL BE LIMITED TO AN AMOUNT EQUAL TO THE PRESENT PURCHASE PRICE FOR THE SWENSON PRODUCT. SWENSON SHALL NOT BE LIABLE FOR ANY LOSS OR DAMAGE, WHETHER DIRECT OR INDIRECT, INCIDENTAL, CONSEQUENTIAL OR OTHERWISE ARISING OUT OF BREACH OF THIS WRITTEN WARRANTY OR ANY IMPLIED WARRANTY. Some states do not allow limitations on how long an implied warranty will last or the exclusion or limitation of incidental or consequential damages.

Defective parts returned to Swenson Spreader LLC must be accompanied by the following information:

RG# # _____
Spreader Model _____
Serial Number _____
Date Installed _____
Where Purchased _____

Purchaser accepts these terms and warranty limitations unless product is returned within fifteen days for full refund of purchase price.



SWENSON SPREADER LLC
P.O. BOX 127
LINDENWOOD, ILLINOIS 61049-0127

PHONE: (815)393-4455
TOLL FREE: (888)825-7323
SALES & SERVICE FAX: (866)310-0300

email: swensonsales@swensonspreader.com
website: www.swensonspreader.com

**IMPORTANT
INFORMATION
ENCLOSED**

