

SUBJECT: Briggs and Stratton Voltage Regular Retrofit

To all concerned:

Issue: An issue with unregulated voltage causing damage to the wireless receiver box connected to Briggs and Stratton engines has been reported.

Action: An approved retrofit for installing a voltage regulator to existing units with Briggs and Stratton engines has been designed.

Procedure:

B&S VOLTAGE REGULATOR RETROFIT INSTRUCTIONS



DISCONNECT BATTERY BEFORE SERVICING YOUR EQUIPMENT



ALL ELECTRICAL TERMINAL COVERS MUST BE REPLACED BEFORE BATTERY IS RECONNECTED

ASSEMBLY INSTRUCTIONS

1. DISCONNECT BATTERY. LOCATE RED WIRE ATTACHED TO BATTERY SIDE OF STARTER SOLENOID, AND REMOVE FROM SOLENOID. NOTE: THIS WIRE CONTAINS TWO DIODES
2. UNPLUG OTHER END OF RED WIRE FROM ENGINE CHARGE WIRE, AND DISCARD.
3. MOUNT ITEM #1 USING ITEM #2 (2) DIRECTLY TO MOUNTING SURFACE (PART OF THE OIL DIPSTICK ASSEMBLY). NOTE: GROUND REGULATOR BY INSTALLING ITEM #4 UNDER BOTTOM SCREW.
4. ATTACH YELLOW WIRE ON REGULATOR TO THE ENGINE CHARGE WIRE, AND ATTACH THE RED WIRE ON REGULATOR TO ITEM #3.
5. ATTACH RING TERMINAL OF ITEM #3 TO BATTERY SIDE OF STARTER SOLENOID.
6. ATTACH REMAINING END OF ITEM #4 TO ENGINE MOUNTING BOLT.
7. REPLACE ALL GUARDS, AND ELECTRICAL TERMINAL COVERS BEFORE RECONNECTING BATTERY.

ITEM	PART NUMBER	DESCRIPTION	QTY.
1	04144-257-00	REGULATOR, VOLTAGE	1
2	04144-258-00	SCREW	2
3	04616-116-00	WIRE, RED JUMPER	1
4	04616-117-00	WIRE, WHITE JUMPER	1

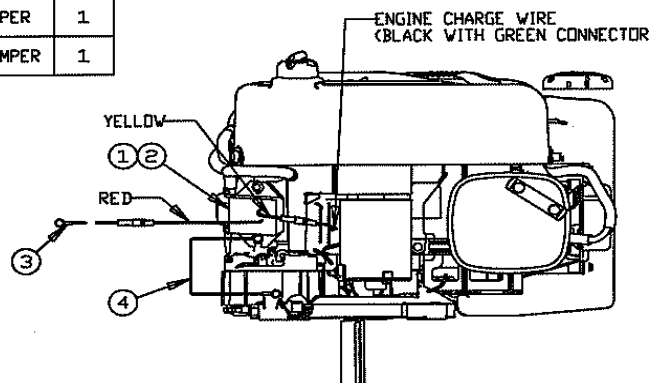

Swenson Products, LLC. | 127 N. Walnut St. Lindenwood, IL 61049 | 888-825-7323 | swensonproducts.com

Swenson Products LLC assumes no responsibility for installations not made according to these instructions.

		Route To:		
Initial	President/Owner	Sales Manager	Service Manager	Parts Manager

Swenson Products, LLC. | 127 N. Walnut St. Lindenwood, IL 61049 | 888-825-7323 | swensonproducts.com

Swenson Products LLC assumes no responsibility for installations not made according to these instructions.